

**COUNTY OF SAN MATEO  
PLANNING AND BUILDING DEPARTMENT**

**DATE:** February 14, 2018

**TO:** Planning Commission

**FROM:** Planning Staff

**SUBJECT:** EXECUTIVE SUMMARY: Consideration of an After-The-Fact Grading Permit for the restoration of a coastal bluff involving approximately 7,200 cubic yards of balanced cut and fill grading, located at 20165 Cabrillo Highway, a developed parcel in the unincorporated San Gregorio area of San Mateo County. This project is located in the Cabrillo Highway State Scenic Corridor. The required Coastal Development Permit for this project is under the permitting authority of the California Coastal Commission.

County File Number: PLN 2013-00495 (Kerry Burke)

**PROPOSAL**

In response to a violation case (VIO 2013-00120) regarding approximately 7,200 cubic yards (c.y.) of fill material illegally excavated from the top of a coastal bluff and then placed onto an adjacent beach area, the applicant has removed the excavated fill material from the beach, placed it back in its original location, and revegetated the area. This project involved approximately 39,750 sq. ft. of land disturbance and was completed in three steps: long-reach excavators and trucks moved the excavated fill material back to its original location; erosion control measures such as reseeding, jute netting, and fiber rolls were installed; and the project area was revegetated with a restoration planting palette composed of dominant species in the coastal scrub vegetation community. San Mateo County (County) issued the applicant a Grading Permit Exemption and the California Coastal Commission (CCC) issued an Emergency Coastal Development Permit (CDP) for the coastal bluff repair. As a condition of approval of those permits, the applicant is required to obtain a retroactive Grading Permit and CDP after completion of the emergency work. The retroactive Grading Permit will assess the completed project for its compliance with applicable County regulations. The CDP will be under the permitting authority of the CCC. The applicant submitted the required CDP application to the CCC on November 13, 2013. The CCC will process the CDP upon final County approval of the retroactive Grading Permit.

## **RECOMMENDATION**

That the Planning Commission approve the After-The-Fact Grading Permit, County File Number PLN 2013-00495, by making the required findings and conditions of approval as listed in Attachment A.

## **SUMMARY**

**Setting:** The project parcel is located across from Star Hill Road and approximately 1.43 miles north of the intersection of Highway 1 (Cabrillo Highway) and Highway 84 (La Honda Road). The developed parcel is bounded by the Pacific Ocean to the west and by land to the north, south, and east. Mature trees and vegetation can be found throughout the property. The project site is approximately 980 feet west of the entrance to the project parcel at Highway 1. There is a single-family residence, well pump house, water tanks, and storage buildings on the property which are all located east of the project area. Parcels within the surrounding area are largely undeveloped with some parcels developed sporadically with single-family residential and agricultural uses.

**General Plan Compliance:** The proposed project complies with all applicable General Plan policies regarding Vegetative, Water, Fish, and Wildlife Resources and Soil Resources. The project included the implementation of avoidance measures to mitigate any potential impacts to sensitive habitats. Revegetation monitoring after the grading work was completed determined that the restoration component of the project was successful and no additional actions are recommended. The project was also regulated to minimize soil erosion and sedimentation to ensure stabilization of disturbed areas.

**Local Coastal Program Compliance:** The project was reviewed and found to be in compliance with all applicable Local Coastal Program policies regarding Sensitive Habitats. No sensitive species were observed during the pre-construction and construction stage of the project. The project was mitigated and routinely monitored to ensure that there were no significant adverse impacts on sensitive habitat areas. It was determined that the restoration component of this project was successful and no additional actions are recommended.

**Zoning Compliance:** The project involves approximately 7,200 c.y. of grading to restore a coastal bluff on the subject parcel. No development or use is proposed as part of the subject application, therefore no PAD Permit is required.

**Grading Permit:** The project complies with all applicable standards in the County Building Regulations regarding grading which includes erosion and sediment control, dust control, and timing of grading activity. The project has also been reviewed and approved by the Geotechnical Section.

CJM:jlh – CJMBB0740\_WJU.DOCX

**COUNTY OF SAN MATEO  
PLANNING AND BUILDING DEPARTMENT**

**DATE:** February 14, 2018

**TO:** Planning Commission

**FROM:** Planning Staff

**SUBJECT:** Consideration of an After-The-Fact Grading Permit, pursuant to Section 9298 of the San Mateo County Building Regulations, for the restoration of a coastal bluff involving approximately 7,200 cubic yards of balanced cut and fill grading, located at 20165 Cabrillo Highway, a developed parcel in the unincorporated San Gregorio area of San Mateo County. This project is located in the Cabrillo Highway State Scenic Corridor. The required Coastal Development Permit for this project is under the permitting authority of the California Coastal Commission.

County File Number: PLN 2013-00495 (Kerry Burke)

**PROPOSAL**

In response to a violation case (VIO 2013-00120) regarding approximately 7,200 cubic yards (c.y.) of fill material illegally excavated from the top of a coastal bluff and then placed onto an adjacent beach area, the applicant has removed the excavated fill material from the beach, placed it back in its original location, and revegetated the area. This project involved approximately 39,750 sq. ft. of land disturbance and was completed in three steps: long-reach excavators and trucks moved the excavated fill material back to its original location; erosion control measures such as reseeding, jute netting, and fiber rolls were installed; and the project area was revegetated with a restoration planting palette composed of dominant species in the coastal scrub vegetation community. The palette represented many of the species that were likely to be present prior to the disturbance of the area. San Mateo County (County) issued the applicant a Grading Permit Exemption and the California Coastal Commission (CCC) issued an Emergency Coastal Development Permit (CDP) for the coastal bluff repair. As a condition of approval of those permits, the applicant is required to obtain a retroactive Grading Permit and CDP after completion of the emergency work. The retroactive Grading Permit will assess the completed project for its compliance with applicable County regulations. The CDP will be under the permitting authority of the CCC. The applicant submitted the required CDP application to the CCC on November 13, 2013. The CCC will process the CDP upon final County approval of the retroactive Grading Permit.

## **RECOMMENDATION**

That the Planning Commission approve the After-The-Fact Grading Permit, County File Number PLN 2013-00495, by making the required findings and conditions of approval as listed in Attachment A.

## **BACKGROUND**

Report Prepared By: Carmelisa Morales, Project Planner, 650/363-1873

Applicant: Kerry Burke

Owner: Chhmb LLC

Location: 20165 Cabrillo Highway, Half Moon Bay

APN: 081-060-070

Size: 23 acres

Existing Zoning: PAD/CD (Planned Agricultural District/ Coastal Development)

General Plan Designation: Agriculture Rural

Local Coastal Plan Designation: Agriculture

Sphere-of-Influence: None

Existing Land Use: Agriculture

Water Supply: An existing domestic water well on the parcel serves the existing single-family residence.

Sewage Disposal: The site is currently improved with an on-site septic system which services the existing single-family residence. No change to the septic system is proposed.

Flood Zone: The project site is located in Flood Zone X as defined by FEMA (Community Panel Number 06081C0357F, dated August 2, 2017), which is an area with minimal potential for flooding. The beach area below the coastal bluff is designated as Flood Zone VE, a coastal area with 1% or greater chance of flooding and an additional hazard associated with storm waves. This area has a 26% chance of flooding over the life of a 30-year mortgage.

Environmental Evaluation: Categorically exempt under provisions of Class 1, Section 15301, of the California Environmental Quality Act (CEQA) Guidelines for repair



and maintenance of existing topographical features involving no expansion of use, and Class 33, Section 15333, of the CEQA Guidelines for the restoration and stabilization of a coastal bluff and revegetation of the disturbed areas with native plant species.

Setting: The project parcel is located across from Star Hill Road and approximately 1.43 miles north of the intersection of Highway 1 (Cabrillo Highway) and Highway 84 (La Honda Road). The developed parcel is bounded by the Pacific Ocean to the west and by land to the north, south, and east. Mature trees and vegetation can be found throughout the property. The project site is approximately 980 feet west of the entrance to the project parcel at Highway 1. There is a single-family residence, well pump house, water tanks, and storage buildings on the property which are all located east of the project site. Parcels within the surrounding area are largely undeveloped with some parcels developed sporadically with single-family residential and agricultural uses.

Chronology:

<u>Date</u>	<u>Action</u>
July 23, 2013	- Violation case opened (VIO 2013-00120) to investigate the unpermitted excavation of the coastal bluff on the subject parcel.
August 8, 2013	- Application for Emergency Coastal Development Permit and Grading Permit Exemption (PLN 2013-00341) submitted to the County.
August 23, 2013	- The CCC recommended a consolidated CDP for the project under the permitting authority of the CCC.
August 30, 2013	- The County authorized the CCC to act as lead agency for the CDP.
September 12, 2013	- The CCC issued an Emergency CDP (No. G-2-13-0212) for the project.
October 7, 2013	- The County issued a Grading Permit Exemption (PLN 2013-00341) for the project.
October 12, 2013	- Restoration work for the project initiated.
November 13, 2013	- Application for a CDP (No. G-2-13-1111) submitted to the CCC.
December 6, 2013	- Application for an After-The-Fact (ATF) Grading Permit (PLN 2013-00495), the subject of this application, submitted.

- February 2014 - May 2017 - Following the coastal bluff restoration work, eight (8) site visits were conducted by WRA Environmental Consultants to assess the progression of vegetation maturation of the project area.
- August 1, 2017 - Application deemed complete.
- February 14, 2018 - Planning Commission public hearing date.

## **DISCUSSION**

### **A. KEY ISSUES**

#### **1. Issuance of the Emergency Coastal Development Permit and Grading Permit Exemption**

On July 23, 2013, a violation case (VIO 2013-00120) was opened for the illegal grading activity on the subject parcel that was conducted without the benefit of required permits. Approximately 7,200 c.y. of fill material was found to be illegally excavated from the top of a coastal bluff on the subject parcel and placed on the beach area adjacent to the bluff to form a wedge of uncompacted fill measuring approximately 50 feet tall. The majority of the vegetation, northern coastal scrub dominated by coyote brush, was removed. No wetlands, streams, or riparian habitats were observed in the area.

The applicant submitted applications for an Emergency Coastal Development Permit and a Grading Permit Exemption on August 8, 2013 to remove the illegally placed fill material and restore the damaged area. The proposal indicated that the fill material would be removed from the beach area and placed back in its original location. Erosion controls measures would be installed and monitored by Sigma Prime Geosciences, Inc. (Sigma Prime). The project area would then be revegetated with a restoration planting palette composed of dominant species in the coastal scrub vegetation community. This palette would represent many of the species that were likely to be present prior to the disturbance of the area. The drainage system would be adjusted as needed.

A biotic assessment prepared by Michael Josselyn, Ph.D., P.W.S. of WRA Environmental Consultants (WRA) (see Attachment D) and a geotechnical report prepared by Charles Kissick, P.E. of Sigma Prime were submitted with the application (see Attachment E). The Grading Permit Exemption (see Attachment G) was conditioned to require the installation of avoidance and erosion control measures as detailed in the Restoration Plan (see Attachment C).

As discussed in the letter of decision for the Grading Permit Exemption, the proposal complied with Section 9298.4 (*Restoration or Remedial Work*) of the County Building Regulations (formerly Section 8603.10 (*Emergency Work*) of the County Grading and Land Clearing Regulations) to remediate the grading violation. The CCC recommended a consolidated CDP for the project under the permitting authority of the CCC. On August 30, 2013, the County authorized the CCC to act as lead agency for the CDP. The CCC issued an Emergency CDP (CDP G-2-13-2012) (see Attachment F) for the project on September 12, 2013 and the County issued a Grading Permit Exemption on October 7, 2013 (see Attachment G). The approval was conditioned to require the applicant to submit an application for an ATF Grading Permit within sixty (60) days of the issuance of the Grading Permit Exemption. Compliance of the project with all applicable policies for the ATF Grading Permit is discussed in the subsequent sections below.

## 2. Conformance with the General Plan

Upon review of the applicable provisions of the General Plan (GP), staff has determined that the project complies with all GP policies, including the following:

### Vegetative, Water, Fish, and Wildlife Resources

Policy 1.28 (*Regulate Development to Protect Sensitive Habitats*) aims to regulate land uses and development activities within and adjacent to sensitive habitats in order to protect critical vegetative, water, fish, and wildlife resources, protect rare, endangered, and unique plants and animals from reduction in their range or degradation of their environment, and protect and maintain the biological productivity of important plant and animal habitats.

The first biotic assessment, prepared by Josselyn of WRA (see Attachment D) for the Grading Permit Exemption, summarizes the observations and findings of the site visit conducted by Leslie Lazarotti, M.S., of WRA to the project area on July 29, 2013. The report states that the majority of vegetation removed consisted of northern coastal scrub dominated by coyote brush, a common shrubland alliance on the California coast. No wetlands, streams, or riparian habitat were observed in the project area. Although no California Natural Diversity Database (CNDDDB) records for federal or state listed plant or wildlife species were known to have occurred on the project site, it was determined that potential habitat may exist for some species. Sensitive species in the surrounding vicinity were evaluated for their potential to occur within or near the project area. The following fourteen (14) species were identified: San Bruno Mountain manzanita, Montara manzanita, Pacific manzanita, Kings Mountain manzanita, San Francisco Bay spineflower, Franciscan thistle, Mission bells, San Francisco

gumplant, shortleaf dwarf cudweed, coast yellow leptosiphon, rose leptosiphon, Hickman's cinquefoil, San Francisco campion, and coastal triquetrella. Josselyn recommended a restoration program and mitigation measures to reduce further impacts to these species during the restoration work for the project area. The measures included immediate stabilization and erosion control on graded areas, soil testing and soil amendment, a revegetation program consisting of a native coastal grass seed mix, and monitoring and reporting at monthly intervals during the upcoming rainy season.

The second biotic assessment, prepared by Lazarotti of WRA for the ATF Grading Permit, included a summary of the site visits, repairs, and progression of vegetation regrowth of the project area (see Attachment N). Revegetation was implemented in two phases in 2013. The first phase involved placement of native soil and biodegradable matting/bars immediately following the completion of grading. The second phase involved planting and seeding prior to the onset of the 2013-2014 rainy season. There were no rain events that occurred during the restoration work. Once the restoration phase was completed, no drainage work was conducted to allow for the natural recurving of drainage channels with the present topography. Access trails were preserved for monitoring purposes.

WRA conducted eight (8) site visits to assess the progression of vegetation maturation within the project area. The site visits were conducted on February 21, April 11, and August 25, 2014, April 9 and June 29, 2015, June 3, 2016, and January 19 and May 1, 2017. The project area was found to progressively increase in vegetative cover. The vegetation was dominated by the following native species: meadow barley, seaside woolly, yellow bush lupine, poison oak, and coyote brush. With the exception of meadow barley, which was included in the restoration planting palette, these species were naturally recruited, either by the existing seedbank or local dispersal, into suitably restored habitat conditions. The non-native species present within the project area included tall fescue, sea fig, bull thistle, and common mustard. The plant species composition within the project area is comparable to the composition of surrounding coastal scrub habitat.

Drainage paths were found to be following the natural ridges in the topography as early as June 24, 2015. No erosion events within the project area were observed. Some erosion could be seen on the outer edge of the coastal bluff due to the area recalibrating natural drainage paths. However, Lazarotti found that the erosion did not appear to have increased since it was noted in 2014. The 2016-2017 rainy season consisted of extremely wet and prolonged rain events. No notable disturbance was observed at the end of this rainy season. The project area has proved to be fairly stable, most likely due to its vegetated state.

Lazarotti concluded in the second biotic assessment that the native coastal seed mix planted was successful in revegetating the project area and encouraging the growth of additional native plants not included in the original mix. The project site continues to become more vegetated. The fully vegetated natural drainage patterns are present along the natural furrows and any additional plant growth will further minimize future erosion potential of the project area. The project has completed the restoration of the project area and thus no additional actions are recommended.

### Soil Resource Policies

Policy 2.17 (*Regulate Development to Minimize Soil Erosion and Sedimentation*) aims to regulate development to minimize soil erosion and sedimentation including, but not limited to, measures which consider the effects of slope, minimize removal of vegetative cover, and ensure stabilization of disturbed areas and protect and enhance natural plant communities and nesting and feeding areas of fish and wildlife. Policy 2.23 (*Regulated Excavation, Grading, Filling, and Land Clearing Activities Against Accelerated Soil Erosion*) further regulates excavation, grading, filling, and land clearing activities to protect against accelerated soil erosion and sedimentation.

The first geotechnical report, prepared by Kissick of Sigma Prime (see Attachment E) for the Grading Permit Exemption, summarizes observations of the unpermitted work and restoration recommendations. Kissick stated that the project site is in an actively eroding and degrading environment and that the restoration project is not meant to create maximum, long-term slope stability. Erosion control measures were recommended by Sigma Prime as shown in the Restoration Plan (see Attachment C) submitted to minimize any further impact caused by the unpermitted grading work. Sigma Prime was on-site to consult with the earthwork contractor and observe the restoration work.

Upon completion of the restoration work, the applicant submitted an As-Built Plan (see Attachment H) which shows the present state of the project area and the erosion control measures installed. A final grading letter prepared by Kissick (see Attachment I) verifying the restoration work completed was also submitted.

The applicant submitted a second geotechnical report, prepared by Kissick of Sigma Prime (see Attachment M), which summarizes findings from a April 21, 2017 site visit to check on the effectiveness of the erosion control measures and revegetation program that was performed in Fall 2013. A Complete Restoration As-Graded Plan (see Attachment L) was also submitted to show the current conditions of the project area. Kissick stated that Sigma Prime has conducted annual visits to the project site to monitor

the erosion control measures. He found that the erosion control measures were working effectively and that there were no gullies, rills, or other signs of erosion. The edge of the bluff exhibits no excessive erosion features. The installed erosion control measures have achieved the desired results. Due to the success of the restoration and after observation over three winter seasons, Kissick states that the project site has been restored to its original condition and no additional measures are recommended.

3. Conformance with the Local Coastal Program

Based on the project proposal, restoration of a coastal bluff, a CDP is required pursuant to Section 6328.4 of the County Zoning Regulations for development in the Coastal Development (CD) District. Staff has determined that the project is in compliance with all applicable Local Coastal Program (LCP) Policies, specifically Policy 7.3a (*Protection of Sensitive Habitats*) which prohibits any land use or development which would have a significant adverse impact on sensitive habitat areas. Further, Policy 8.10 (*Vegetative Cover* (with the exception of crops grown for commercial purposes)) requires that vegetation removed during construction be replaced with plant materials (trees, shrubs, ground cover) that are compatible with surrounding vegetation and is suitable to the climate, soil, and ecological characteristics of the area. As discussed in the sections above, avoidance and erosion control measures were recommended by WRA and Sigma Prime and implemented to ensure that further impacts to sensitive habitats were mitigated. Lazarotti of WRA found that the native coastal seed mix was effective in revegetating the project area and encouraging growth of additional native plants. Natural drainage patterns have also been formed. Kissick of Sigma Prime monitored the erosion control measures on an annual basis and found no signs of erosion. The project was mitigated and routinely monitored to ensure that there were no significant adverse impacts on sensitive habitat areas. Lazarotti and Kissick concluded that the restoration project was successful and no additional measures are required.

Compliance with LCP policies will be further analyzed by the CCC as part of the CDP review. The applicant submitted the required CDP application to the CCC on November 13, 2013. The CCC will process the CDP only after final County approval of the retroactive Grading Permit.

4. Conformance with the Planned Agricultural District Regulations

The subject parcel is zoned PAD/CD (Planned Agricultural District (PAD)/Coastal Development). The parcel does not contain prime soils, but is identified as having lands suitable for agriculture. Section 6353 (*Uses Permitted Subject to the Issuance of a Planned Agricultural Permit*) of the County Zoning Regulations states that single-family residences and

associated development are allowed on Land Suitable for Agriculture and Other Lands subject to the issuance of a PAD Permit. The existing single-family residence was approved (Case Nos. CDP 82-3 and UP 82-2) and built in the 1980s. The current project involves approximately 7,200 c.y. of grading to restore a coastal bluff on the subject parcel. No development or use is proposed as part of the subject application, therefore no PAD Permit is required.

5. Conformance with the Grading Regulations

The applicant has restored a coastal bluff top, a project involving approximately 7,200 c.y. of grading, on the subject parcel. Pursuant to Sections 9283 (*Permit Requirements*) and 9284 (*Exemptions*) of the County Building Regulations, the proposed project does not qualify for any Grading Permit exemptions and therefore requires a Grading Permit. Due to the location of the subject parcel within the Cabrillo Highway State Scenic Corridor, the project is appealable to the CCC and subject to the review of the Planning Commission.

In order to approve this Grading Permit, the Planning Commission must make the required findings as specified in Section 9290 (*Findings, Conditions, and Actions*) of the County Building Regulations. The findings and supporting evidence are outlined below:

**a. That the project will not have a significant adverse effect on the environment.**

Section 21084 of the Public Resources Code requires that the CEQA Guidelines include a list of classes of projects which have been determined not to have a significant effect on the environment and which shall be exempt from the provisions of CEQA. This project is categorically exempt under provisions of Class 1, Section 15301, of the California Environmental Quality Act (CEQA) Guidelines for repair and maintenance of existing topographical features involving no expansion of use, and Class 33, Section 15333, of the CEQA Guidelines for the restoration and stabilization of a coastal bluff and revegetation of the disturbed areas with native plant species.

**b. That the project conforms to the criteria of Chapter 5 (*Regulations for Excavating, Grading, Filling, and Clearing on Lands in Unincorporated San Mateo County*) of the San Mateo County Building Regulations including the standards referenced in Section 9296.**

The project, as conditioned, conformed to the standards in Chapter 5 of the San Mateo County Building Regulations, including erosion and

sediment control, dust control, and timing of grading activity. A Restoration Plan (see Attachment C) with erosion control and dust control measures was submitted and approved for the Grading Permit Exemption. As discussed in the sections above, erosion control measures were implemented prior to the start of the restoration work and additional measures were not required due to the successful revegetation growth of the project. No additional erosion control measures or actions were recommended by the project consultants. Lastly, the project also included conditions of approval requiring the implementation of dust control measures and timing restrictions for grading activities.

**c. That the project is consistent with the General Plan.**

As discussed in Section A.1 above, the project, as conditioned, complied with all applicable General Plan policies specifically regarding vegetative, water, fish, and wildlife resources and soil resources. The project has successfully restored the coastal bluff on the subject parcel and no additional actions are recommended.

**B. REVIEW BY THE CALIFORNIA COASTAL COMMISSION**

The California Coastal Commission (CCC) responded to staff's referrals for this project with letters dated December 12, 2013 and January 6, 2014 (see Attachments J and K). Both letters state that the CDP application submitted by the applicant on November 13, 2013 cannot be processed by the CCC until the project obtains final County approval for the ATF Grading Permit. Both letters also outline the CCC's primary concerns with the project regarding drainage and revegetation. The CCC requests that the applicant identify the location of the buried spring relative to the restoration area and describe how permanent drainage of the project site will be addressed. The CCC also requests that a revegetation plan and a monitoring plan of the progress and success of the revegetation be submitted.

As discussed in the sections above, the applicant has submitted documents addressing the concerns of the CCC. The second geotechnical report prepared by Kissick of Sigma Prime (see Attachment M) addressed the drainage conditions of the project site and the biotic assessments prepared by Josselyn and Lazarotti of WRA (see Attachments D and N) included a revegetation plan and summary and findings from the site visits conducted from 2014 to 2017 after the restoration work was completed. The project consultants determined that the restoration project was successful and no additional actions were recommended.



C. ENVIRONMENTAL REVIEW

This project is categorically exempt pursuant to Section 15301, Class 1, of the California Environmental Quality Act (CEQA) Guidelines related to the repair and maintenance of existing topographical features involving no expansion of use, and Class 33, Section 15333, of the CEQA Guidelines for the restoration and stabilization of a coastal bluff and revegetation of the disturbed areas with native plant species.

D. REVIEWING AGENCIES

Department of Public Works  
Geotechnical Section

ATTACHMENTS

- A. Conditions of Approval
- B. Site Map
- C. Restoration Plan, dated August 8, 2013
- D. Biotic Assessment prepared by Michael Josselyn, Ph.D., P.W.S. of WRA Environmental Consultants, dated August 7, 2013
- E. Geotechnical Report prepared by Charles N. Kissick, P.E. of Sigma Prime Geosciences, Inc., dated August 14, 2013
- F. California Coastal Commission Emergency Coastal Development Permit, dated September 12, 2013
- G. San Mateo County Planning and Building Department Grading Permit Exemption Letter of Decision, dated October 7, 2013
- H. As-Built Plan, dated November 11, 2013
- I. Final Grading Letter prepared by Charles N. Kissick, P.E. of Sigma Prime Geosciences, Inc., dated November 12, 2013
- J. California Coastal Commission Letter, dated December 12, 2013
- K. California Coastal Commission Letter, dated January 6, 2014
- L. Complete Restoration As-Graded Plan, dated May 3, 2017
- M. Geotechnical Report prepared by Charles N. Kissick, P.E. of Sigma Prime Geosciences, Inc., dated May 10, 2017
- N. Biotic Assessment prepared by Leslie Lazarotti, M.S. of WRA Environmental Consultants, dated May 12, 2017

CJM:jlh – CJMBB0741\_WJU.DOCX

County of San Mateo  
Planning and Building Department

**RECOMMENDED FINDINGS AND CONDITIONS OF APPROVAL**

Permit or Project File Number: PLN 2013-00495      Hearing Date: February 14, 2018

Prepared By: Carmelisa Morales  
Project Planner

For Adoption By: Planning Commission

**RECOMMENDED FINDINGS**

Regarding the Environmental Review, Find:

1. That this project is categorically exempt from environmental review, pursuant to Class 1, Section 15301, of the California Environmental Quality Act (CEQA) Guidelines for the repair and maintenance of existing topographical features involving no expansion of use, and Class 33, Section 15333, of the CEQA Guidelines for the restoration and stabilization of a coastal bluff and revegetation of the disturbed areas with native plant species.

Regarding the After-The-Fact Grading Permit, Find:

2. That the granting of the permit will not have a significant adverse effect on the environment. The project is categorically exempt under provisions of Class 1, Section 15301, of the California Environmental Quality Act (CEQA) Guidelines for repair and maintenance of existing topographical features involving no expansion of use, and Class 33, Section 15333, of the CEQA Guidelines for the restoration and stabilization of a coastal bluff and revegetation of the disturbed areas with native plant species.
3. That the project conforms to the criteria of Chapter 5 of the San Mateo County Building Regulations, including the standards referenced in Section 9296. The project, as proposed and conditioned, conformed to the standards in the Building Regulations, including erosion and sediment control, dust control, and timing of grading activity. Erosion control measures were implemented prior to the start of the restoration work and additional measures were not required due to the successful revegetation growth of the project area. The project has been reviewed and approved by the Geotechnical Section.

4. That the project is consistent with the General Plan, specifically regarding vegetative, water, fish, and wildlife resources and soil resources. The project has successfully restored the coastal bluff on the subject parcel and no additional actions are recommended. Conditions of approval have been provided to ensure that the grading operations minimize erosion and sedimentation resulting from the project.

## **RECOMMENDED CONDITIONS OF APPROVAL**

### **Current Planning Section**

1. The approval applies only to the proposal as described in this report and materials submitted for review and approval by the Planning Commission on February 14, 2018. The Community Development Director may approve minor revisions or modifications to the project if they are found to be consistent with the intent of and are in substantial conformance with this approval.
2. The Coastal Development Permit (CDP) for this project shall be under the permitting authority of the California Coastal Commission (CCC). Within thirty (30) days of final approval of this After-The-Fact Grading Permit, the property owner shall apply for a CDP from the CCC.
3. This permit does not allow for the removal of any trees. Any tree removal will require a separate permit.

CJM;jlh – CJMBB0741\_WJU.DOCX







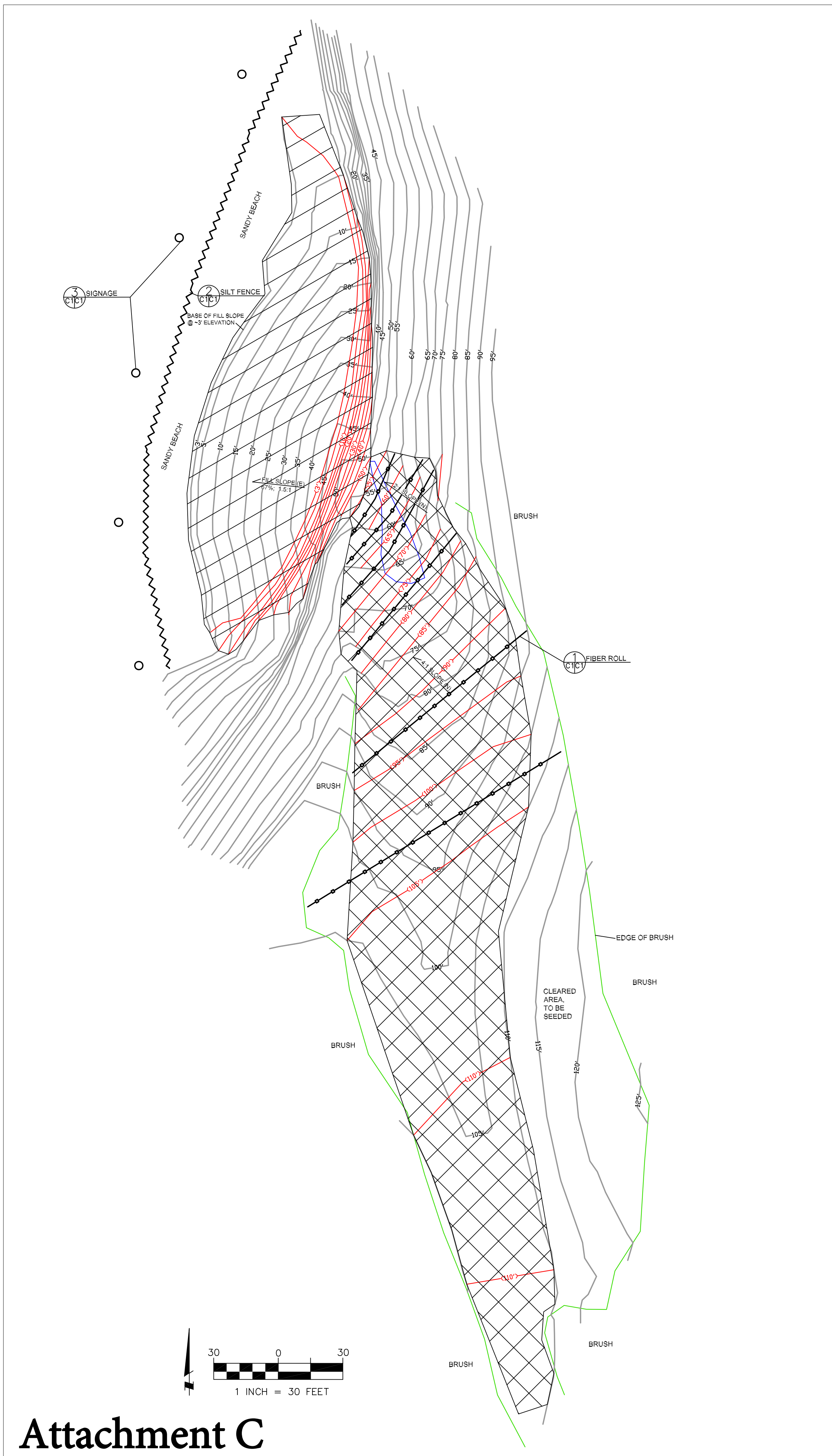

# Attachment C

## LEGEND

- EXISTING 5' CONTOURS
- PROPOSED 5' CONTOURS
- CUT
- FILL

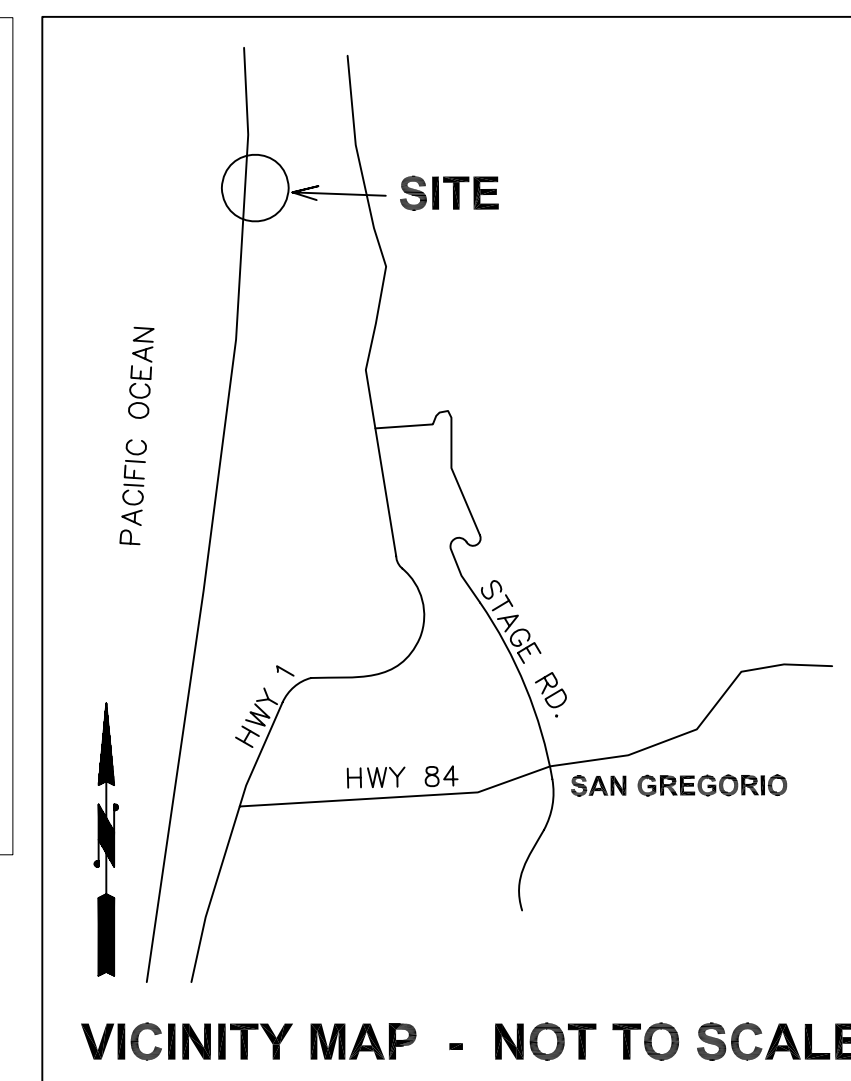
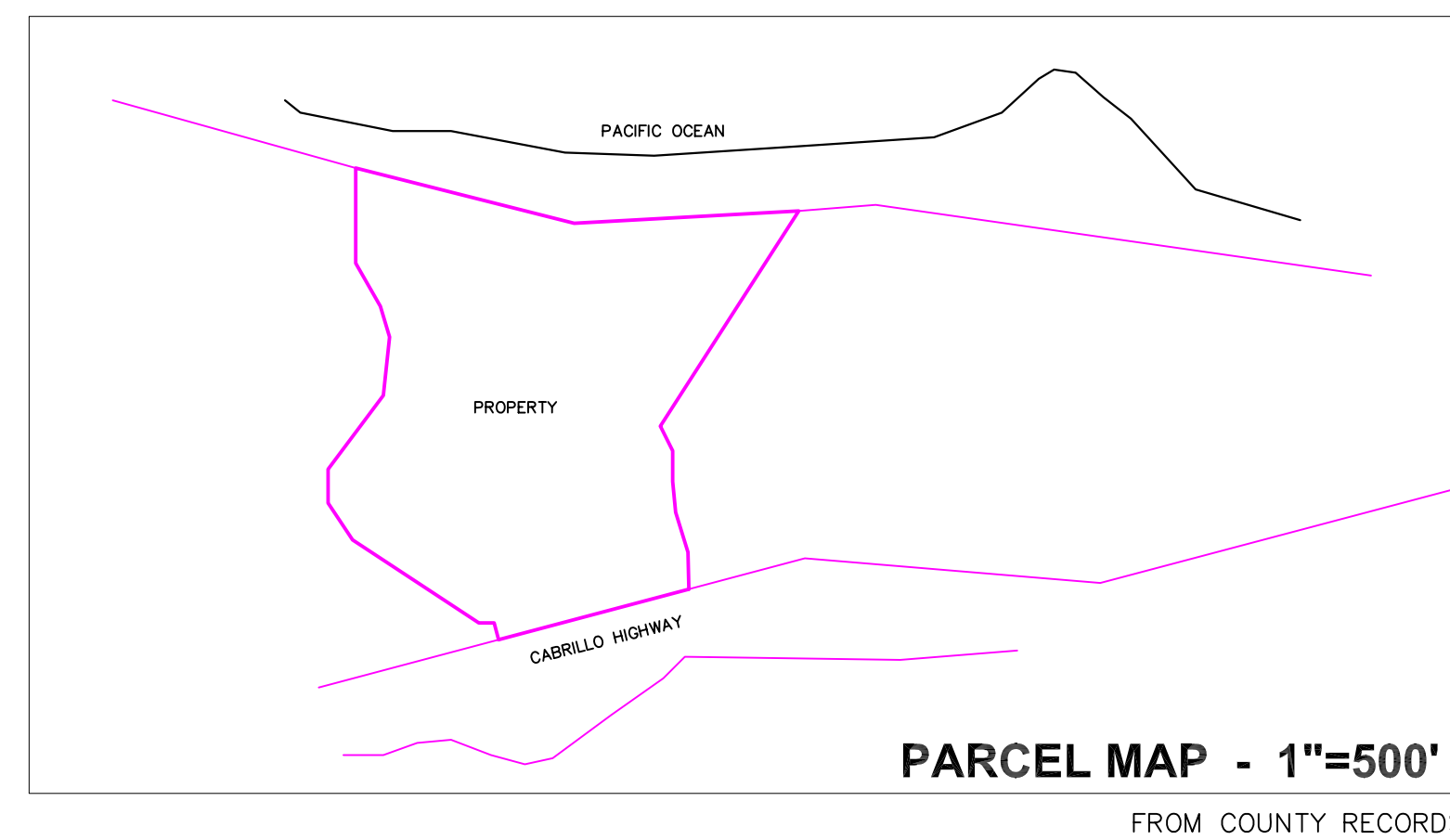

## GENERAL NOTES

1. THE PURPOSE OF THE PROJECT IS TO RESTORE THE AREA TO THE PRE-CONSTRUCTION CONDITION. THE CONSTRUCTION PROJECT CONSISTED OF MOVING SOIL FROM ABOVE THE SEA BLUFF AND CREATING AN EARTHFILL EMBANKMENT. THE FILL MATERIAL ON THE BEACH MUST BE MOVED BACK TO THE TOP OF THE SEA BLUFF. THE SEA BLUFF THAT IS NOW BURIED WAS NEARLY VERTICAL; THE NEW SEA BLUFF SHALL MATCH THE ORIGINAL SEA BLUFF BEFORE BURIAL.
2. WORK DURATION EXPECTED TO BE ABOUT 4 WEEKS FROM NOTICE TO PROCEED. WORK SHOULD BE COMPLETED BY OCTOBER 1.
3. PLANS PREPARED AT THE REQUEST OF:  
DANTE SILVESTRI AND KERRY BURKE, OWNER REPRESENTATIVES.
4. SURVEY AND TOPOGRAPHY BY SIGMA PRIME, JULY 16, 2013.
5. ELEVATION DATUM ASSUMED.
6. THIS IS NOT A BOUNDARY SURVEY.

## DUST CONTROL NOTES

1. APPLY WATER TO ALL LOOSE SOILS THAT ARE BEING DISTURBED TO PREVENT GENERATION OF DUST CLOUDS. THIS INCLUDES SOIL SURFACES THAT EQUIPMENT IS DRIVING ON, AND SOIL THAT IS BEING EXCAVATED OR PLACED.

## GRADING NOTES

CUT VOLUME : 7200 CY  
FILL VOLUME: 7200 CY  
ABOVE VOLUMES ARE APPROXIMATE.

1. PROPOSED EXCAVATION SHALL PROCEED UNTIL ORIGINAL FACE OF SEA BLUFF IS EXPOSED.
2. FILL SHALL BE PLACED IN 12-INCH LOOSE LIFTS AND LIGHTLY TRACK-WALKED FOR NOMINAL COMPACTION (~85%).
3. NEW FILL SLOPES SHALL BE NO STEEPER THAN 2:1.
4. METHOD OF EXCAVATION TO BE LONG-REACH EXCAVATOR, WORKING FROM THE TOP. NO HEAVY EQUIPMENT WILL BE ON BEACH.

## IRRIGATION NOTES

1. IRRIGATION SYSTEM TO INCLUDE TWO TEMPORARY 5000-GALLON WATER TANKS AND LINES TO ESTABLISH VEGETATION AT FILL AREA PER BIOLOGIST RECOMMENDATIONS.
2. TANKS TO BE LOCATED AT TOP OF HILL NEAR HOUSE. FLEXIBLE PLASTIC WATER LINES TO BE RUN OVERLAND TO SPRINKLERS.
3. SPRINKLERS TO BE PLACED TO PROVIDE FULL COVERAGE OF SEEDED AREAS.
4. SPRINKLERS (AND SEEDING) TO BE INCLUDED AT ALL DISTURBED AREAS.

## DRAINAGE NOTES

1. TEMPORARY DEWATERING OF THE NATURAL SEEPAGE FROM THE CLIFF FACE WILL BE ESTABLISHED FOR SAFETY AND STABILITY DURING FILL REMOVAL. METHOD OF DEWATERING WILL BE DECIDED DURING CONSTRUCTION; THERE ARE TOO MANY UNCERTAINTIES AT THIS TIME, REGARDING ELEVATION AND AERIAL EXTENT OF SEEPAGE SOURCE, AS IT IS BURIED BY THE FILL.
2. FINAL FILL SLOPES TO BE UNIFORM AND WITHOUT SWALES, IN ORDER TO PREVENT CONCENTRATION OF SURFACE RUNOFF.

## SECTION AND DETAIL CONVENTION

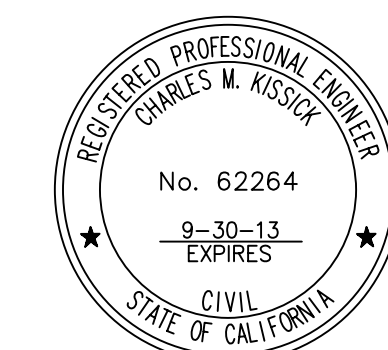
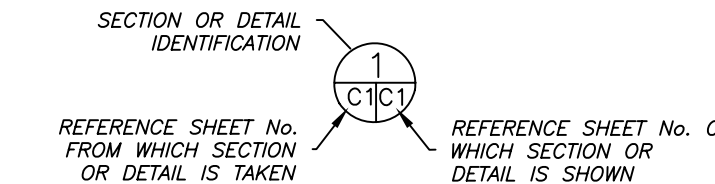

## EROSION CONTROL NOTES

- FIBER ROLL: INSTALL AS SHOWN IN DETAIL 1
- SILT FENCE: INSTALL AT LOCATIONS SHOWN. AFIX AS SHOWN IN DETAIL 2

1. WORK SHOULD BE COMPLETED BY OCTOBER 1.
2. ALL EXPOSED SOIL SHALL BE PROTECTED FROM EROSION AT ALL TIMES. SUCH PROTECTION SHALL CONSIST OF JUTE MATTING AND SEEDING ON SLOPES.
3. ALL STOCKPILED SOIL SHALL BE COVERED DURING PERIODS OF RAIN.
4. AT COMPLETION OF PROJECT ALL EXPOSED OR DISTURBED SURFACES SHALL BE PERMANENTLY PROTECTED FROM EROSION, WITH PLANTING OF NON-INVASIVE GRASSES AND PLANTS AS PER BIOLOGIST RECOMMENDATIONS.
5. FIBER ROLLS TO BE PLACED PARALLEL TO NEW SLOPES TO PREVENT CONCENTRATION OF RUNOFF AND SILT.

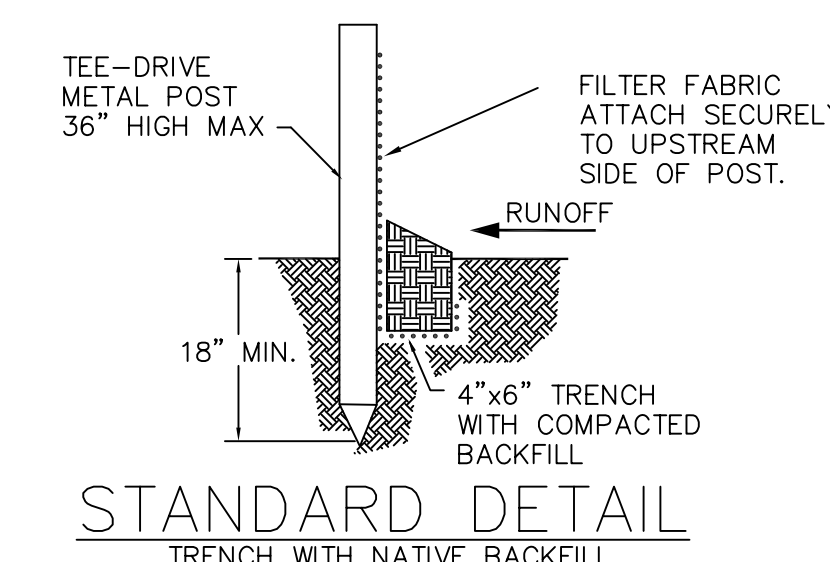
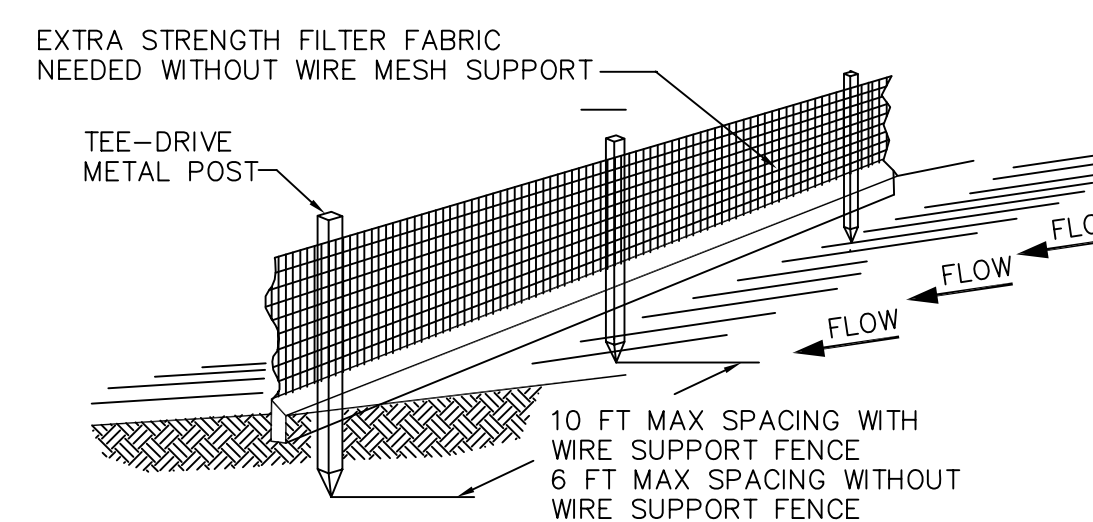
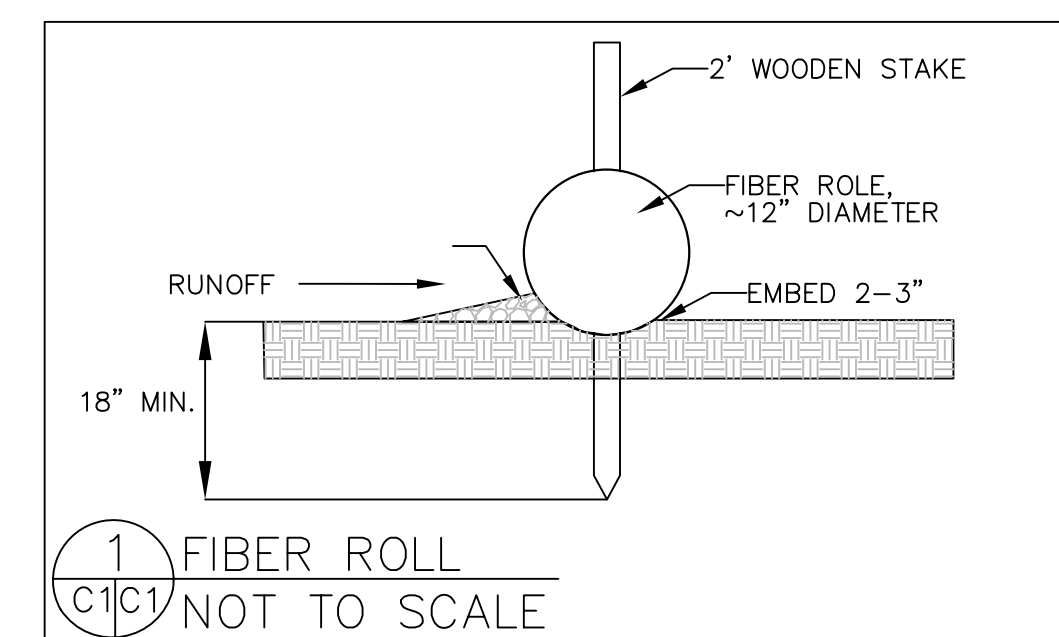

- NOTE:
1. INSPECT AND REPAIR FENCE AFTER EACH STORM EVENT AND REMOVE SEDIMENT WHEN NECESSARY.
  2. REMOVED SEDIMENT SHALL BE DEPOSITED TO AN AREA THAT WILL NOT CONTRIBUTE SEDIMENT OFF-SITE AND CAN BE PERMANENTLY STABILIZED.
  3. SILT FENCE SHALL BE PLACED ON SLOPE CONTOURS TO MAXIMIZE PONDING EFFICIENCY.

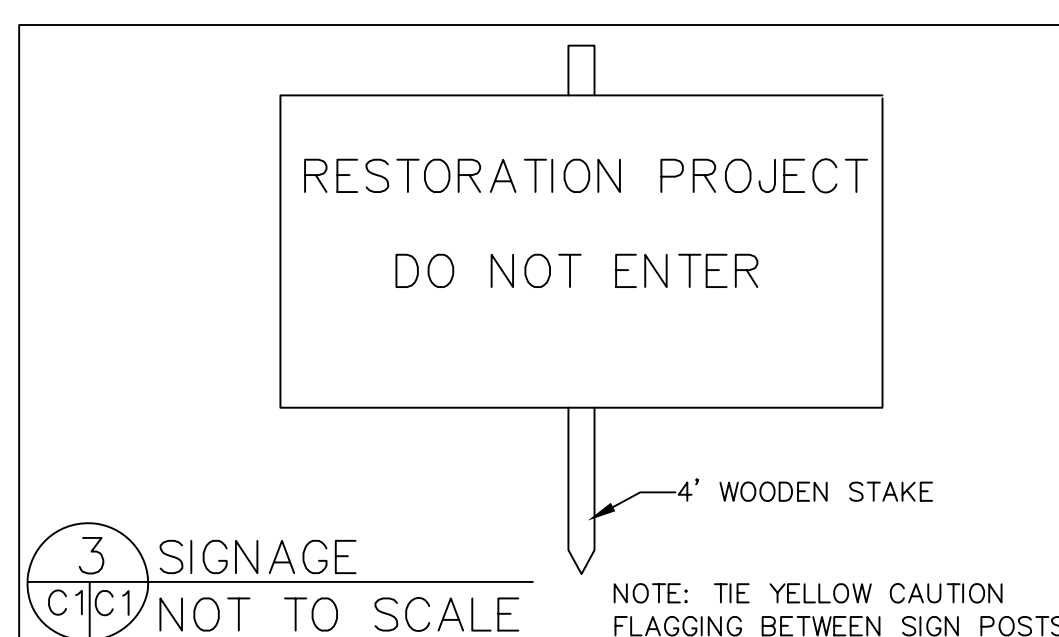

REGISTERED PROFESSIONAL ENGINEER  
CHARLES M. KISSICK  
No. 62264  
9-30-13  
EXPIRES  
CIVIL  
STATE OF CALIFORNIA

DATE: 8-8-13  
DRAWN BY: CMK  
CHECKED BY: AZG  
REV. DATE: 8-14-13  
REV. DATE:  
REV. DATE:

RESTORATION PLAN

CHMB PROPERTY  
20165 CABRILLO HIGHWAY  
SAN GREGORIO

SHEET  
C-1

Sigma Prime Geosciences, Inc.  
SIGMA PRIME GEOSCIENCES, INC.  
111 VASSAR STREET  
HALF MOON BAY, CA 94019  
(650) 728-3590  
FAX 728-3593



August 7, 2013

Chris Wade  
SSL Law Firm LLP  
575 Market Street, Suite 2700  
San Francisco, CA 94105

RE: 20165 So. Cabrillo Hwy. Half Moon Bay

Dear Ms. Wade:

On July 29, 2013, Ms. Leslie Lazarotti, Associate Biologist, with WRA conducted an initial site visit to 20165 So. Cabrillo Hwy to investigate grading activities that have been conducted on the property. The purpose of the visit to evaluate any biological issues and to consider restorative measures as appropriate.

During the visit, Ms. Lazarotti walked the area of the grading and earthmoving activities. Grading has removed the vegetation and topsoil from the coastal terrace, with some of the soil being sidecast and some being placed on the beach and on the coastal bluff face. The majority of the vegetation removed consisted of northern coastal scrub dominated by coyote brush, *Baccharis pilularis*, and is considered as a common shrubland alliance on the California coast<sup>1</sup>. Canopy cover in undisturbed portions of the property was nearly 100% with species cover and density similar to that reported by Baxter and Parker (1999) in their study on coastal scrub communities of the San Mateo coast<sup>2</sup>. No wetlands, streams, or riparian habitat was observed in the area of the earthwork.

No California Natural Diversity Database records for federal or state listed plant or wildlife species occur on this site; however, potential habitat may exist for some species. No investigation for special status species was undertaken during this site visit; however, sensitive species in the vicinity of the project were evaluated for occurrence within the area to be restored and an evaluation of the potential for those species to occur is provided in the attached table (Table 1). It is recommended that once a final restoration plan is developed that more specific recommendations be developed for best management practices to avoid sensitive species.

The coastal bluff at this location is either vertical or was observed to be very steep; but was largely unvegetated. As defined by the Coastal Commission (Title 14, Cal. Code of Regulations, sec. 13577), a seacliff ("coastal bluff") is an escarpment, with a minimum 10-foot height, the toe of which is or may have been subject to marine erosion during the historic record. Sea cliffs occur along the westerly side of the property, where the landform drops to the granitic shoreline terrace. Sea cliffs are considered ESH under the San Mateo County LCP.

Biological restoration of the graded area will require several recommended steps including:

- Immediate stabilization and erosion control on graded areas so that additional soil and rock do not erode on the terrace or onto the beach.
- Development of a grading plan that includes suitable erosion control and slope stabilization

on the exposed earth while revegetation is occurring.

- Soil testing and soil amendment recommendations for soils that will be used for the graded area. WRA recommends organic material amendments and, where possible, inoculation with a native soil mix that will support soil microbial communities typical of northern coastal scrub habitat.
- A revegetation program will need to be initiated immediately after the grading is completed. As an initial recommendation, the following species should be included:

Table 2. Potential Planting Palette

Shrubs	Container Size <sup>1</sup>
Coyote brush ( <i>Baccharis pilularis</i> )	1 gallon
Coastal mugwort ( <i>Artemisia suksdorfii</i> )	6" depot
Blue blossom ( <i>Ceanothus thyrsiflora</i> )	1 gallon
Herbs	Seed Mix
Seaside daisy ( <i>Erigeron glaucus</i> )	6" depot
Seaside wooly sunflower ( <i>Eriophyllum staechadifolium</i> )	6" depot

<sup>1</sup> Container size subject to change based on final construction drawings.

To prevent erosion and facilitate growth of native plant species within the restoration area, a native coastal grass seed mix should be applied to bare soils. A suggested hydroseed mix is included in the table below.

Table 3. Hydroseed Native Seed Mix

Botanical Name	Seed Rate Pounds/Acre
<i>Bromus californica</i>	16
<i>Hordeum californicum</i>	12
<i>Danthonia californica</i>	10
<i>Stipa pulchra</i>	10
<i>Elymus glaucus</i>	10

A more complete revegetation plan will be developed once a grading plan has been developed. The revegetation plan will provide complete plant palettes, container sizes, quantities, seeding rates, planting times, and potential sources. An irrigation plan will also be prepared.

Monitoring and reporting on the status of the restoration plantings should occur at monthly intervals during the rainy season (November 15 to April 15) that follows the initial planting/seeding. Any plants that fail to become established should be promptly replaced. In the event that construction of the restoration project occurs in 2013, the native revegetation planting/seeding of the restoration area should occur in two phases: (1) placement of the native soil and biodegradable erosion control matting/bars immediately following completion of landform restoration construction, and (2) planting and seeding shortly before the forecast onset of the 2013-2014 rainy season.

We understand the importance of working closely with the project team to develop an effective restoration program for this area and will respond as quickly as possible to meet the project needs. Please call me or Leslie Lazarotti with any questions.

Sincerely yours,

A handwritten signature in black ink, appearing to read "MJ", with a long horizontal stroke extending to the right.

Michael Josselyn, PhD PWS  
Principal.

1. Sawyer, J.O., T. Keeler-Wolf, and J. Evens. 2008. A Manual of California Vegetation. Second Edition. California Native Plant Society.
2. Baxter, J.W. and V.T. Parker. 1999. Canopy gaps, zonation, and topographic structure: a northern coastal scrub community on California coastal bluffs. Madrono 46: 69-79.



Table 1. Potential for Special Status Plant and Wildlife Species to Occur at 20165 So. Cabrillo Hwy. Half Moon Bay. List compiled from the California Department of Fish and Game (CDFG) Natural Diversity Database (September 2010), U.S. Fish and Wildlife Service (USFWS) Species Lists, and California Native Plant Society (CNPS) Electronic Inventory search of the Half Moon Bay and surrounding USGS 7.5' quadrangles and a review of other CDFG lists and publications (Jennings and Hayes 1994, Zeiner et al. 1990).

SPECIES	STATUS*	HABITAT	POTENTIAL FOR OCCURRENCE	RECOMMENDATIONS
<b>Mammals</b>				
Pallid Bat <i>Antrozous pallidus</i>	SSC, WBWG High Priority	Found in deserts, grasslands, shrublands, woodlands, and forests. Most common in open, dry habitats with rocky areas for roosting. Sensitive to disturbance of roosting sites.	<b>Unlikely.</b> The vicinity does not support buildings, rocky areas or any other suitable roosting habitat for this species. This species may forage over the vicinity.	No further action necessary.
Townsend's Western Big-eared Bat <i>Corynorhinus townsendii townsendii</i>	SSC, WBWG High Priority	Primarily found in rural settings in a wide variety of habitats including oak woodlands and mixed coniferous-deciduous forest. Day roosts highly associated with caves and mines. Very sensitive to human disturbance.	<b>Unlikely.</b> The vicinity does not support buildings, caves, mines or any other suitable roosting habitat for this species. This species may forage over the vicinity.	No further action necessary.
Fringed Myotis <i>Myotis thysanodes</i>	WBWG High Priority	Associated with a wide variety of habitats including mixed coniferous-deciduous forest and redwood/sequoia groves. Buildings, mines and large snags are important day and night roosts.	<b>Unlikely.</b> The vicinity lacks redwoods, buildings, mines and large snags as roosting habitat for this species. This species may forage over the vicinity.	No further action necessary.
Big Free-tailed Bat <i>Nyctinomops macrootis</i>	SSC, WBWG Medium Priority	Variable, including desert shrub, woodlands, and evergreen forest. Roosts primarily in crevices on cliffs; also utilizes buildings, caves, and tree cavities. Migratory.	<b>No Potential.</b> Typical rocky roost habitat is not present. Nearest documented occurrence is from an unspecified location within Pacifica (CNDDDB 2010).	No further action necessary.
San Francisco Dusky-footed Woodrat <i>Neotoma fuscipes annexens</i>	SSC	Occurs in forest habitats of moderate canopy and moderate to dense understory. Also found in chaparral habitats. Feeds mainly on woody plants: live oak, maple, coffeeberry, alder, and elderberry	<b>Unlikely.</b> The vegetation was investigated during the site visit and no stick houses were observed.	No further action necessary.

SPECIES	STATUS*	HABITAT	POTENTIAL FOR OCCURRENCE	RECOMMENDATIONS
American Badger <i>Taxidea taxus</i>	SSC	Most abundant in drier open stages of most shrub, forest, and herbaceous habitats. Requires friable soils and open, uncultivated ground. Preys on burrowing rodents.	<b>Unlikely.</b> Typical habitat for this species is not present in the vicinity.	No further action necessary.
Ring-tailed Cat <i>Bassariscus astutus</i>	CFP	Ringtails live in a variety of habitats within their range, but they have a decided preference for rocky areas such as rock piles, stone fences, canyon walls, and talus slopes. They occur less commonly in woodland areas where they live in hollow trees and logs, and they are also known to live in buildings	<b>Unlikely.</b> Typical habitat for this species is not present in the vicinity.	No further action necessary.
Southern Sea Otter <i>Enhydra lutris nereis</i>	FT	Nearshore marine environments from about Año Nuevo, San Mateo County. To Point Sal, Santa Barbara County. Needs canopies of giant kelp and bull kelp for rafting and feeding. Prefers rocky substrates with abundant invertebrates.	<b>Unlikely.</b> Sandy beach is only nearshore habitat in graded area.	Monitoring during restoration work to assure no marine mammals present during restoration work
Pacific Harbor Seal <i>Phoca vitulina richardsi</i>	MMPA	Marine and coastal waters, as well as estuaries. Hauls out on coastal rocks, rock reefs, and other habitats relatively isolated from disturbance.	<b>Unlikely.</b> No known haul out area in vicinity to disturbed area.	Monitoring during restoration work to assure no marine mammals present during restoration work
Guadalupe Fur Seal <i>Arctocephalus townsendi</i>	FT, ST, CFP	Breed on Isla de Guadalupe off the coast of Mexico, occasionally found on San Miguel, San Nicolas, and San Clemente islands. Prefers shallow, near shore island water with cool and sheltered rocky areas for haul-outs.	<b>Unlikely.</b> This species is not known to haul out in this area.	No further action necessary.



SPECIES	STATUS*	HABITAT	POTENTIAL FOR OCCURRENCE	RECOMMENDATIONS
Northern Fur Seal <i>Callorhinus ursinus</i>	MMPA	Breeds on large offshore rocks, and along undisturbed rocky or sandy island shorelines. The Farallon Islands are the nearest known breeding site.	<b>Unlikely.</b> This species is not known to haul out in the vicinity.	No further action necessary.
Steller (=northern) Sea Lion <i>Eumetopias jubatus</i>	FT	Breeds on Año Nuevo, San Miguel and Farallon islands, Point Saint George, and Sugarloaf. Hauls-out on islands and rocks. Needs haul-out and breeding sites with unrestricted access to water, near aquatic food supply and with no human disturbance.	<b>Unlikely.</b> This species is not known to haul out in vicinity	No further action necessary.
Northern Elephant Seal <i>Mirounga angustirostris</i>	SMC LCP	This species is the second largest seal in the world, after the Southern Elephant Seal. This species is specifically listed under the San Mateo County Local Coastal program.	<b>Unlikely.</b> This species likely forages off shore but is not known to haul out in the immediate vicinity.	No further action necessary.
<b>Birds</b>				
Harlequin Duck <i>Histrionicus histrionicus</i>	SSC, BLM sensitive	Found in marine waters along rocky shore during non-breeding season. Breeds on west slope of the Sierra Nevada range. Nests in inland streams or along shores of swift, shallow rivers.	<b>Unlikely.</b> This species may forage off shore but does not breed in the vicinity.	No further action necessary.
Common Loon <i>Gavia immer</i>	SSC	Nesting locations at certain large lakes and reservoirs in interior of state, primarily in northeastern plateau region. Bodies of water regularly frequented are extensive, fairly deep, and produce quantities of large fish.	<b>Unlikely.</b> This species may forage off shore but does not breed in the vicinity.	No further action necessary.
Ashy Storm-petrel <i>Oceanodroma homochroa</i>	BCC, SSC	Colonial nester on offshore islands. Nest sites are in crevices beneath loosely piled rocks or driftwood, or in caves. Typically forages west of the continental shelf.	<b>Unlikely.</b> This species does not breed in the vicinity, and occurs within the vicinity only rarely.	No further action necessary.

SPECIES	STATUS*	HABITAT	POTENTIAL FOR OCCURRENCE	RECOMMENDATIONS
California Brown Pelican <i>Pelecanus occidentalis californicus</i>	FE, SE, CFP	Nests colonially on coastal islands of small to moderate size which afford immunity from attack by ground-dwelling predators. Does not breed north of the Channel Islands. Winter visitor and post-breeding dispersant to San Francisco Bay region.	<b>Unlikely.</b> This species does not breed in the vicinity, but may roost in areas along the Mid-Coast shoreline.	No further action necessary.
White-tailed Kite <i>Elanus leucurus</i>	CFP	Year-round resident of coastal and valley lowlands. Preys on small diurnal mammals and occasional birds, insects, reptiles, and amphibians.	<b>Unlikely.</b> This species does not breed in the vicinity, but may roost in areas along the Mid-Coast shoreline.	No further action necessary.
Northern Harrier <i>Circus cyaneus</i>	SSC	Coastal salt and freshwater marsh. Nest and forage in grasslands, from salt grass in desert sink to mountain cienagas. Nests on ground in shrubby vegetation, usually at marsh edge; nest built of a large mound of sticks in wet areas.	<b>Unlikely.</b> This species does not breed in the vicinity, but may roost in areas along the Mid-Coast shoreline.	No further action necessary.
Golden Eagle <i>Aquila chrysaetos</i>	CFP	Year-round resident in rolling foothills with open grasslands, scattered trees, and cliff-walled canyons.	<b>Unlikely.</b> Typical nesting and foraging habitat is not located in the vicinity.	No further action necessary.
Bald Eagle <i>Haliaeetus leucocephalus</i>	FD, SE, CFP	Frequents ocean shores, lake margins, and rivers for both nesting and wintering. Requires abundant fish and adjacent snags or other perches. Nests in large, old-growth, or dominant live tree with open branchwork. Shows a preference for ponderosa pine. Roosts communally in winter.	<b>Unlikely.</b> Typical nesting and foraging habitat is not located in the vicinity.	No further action necessary.



SPECIES	STATUS*	HABITAT	POTENTIAL FOR OCCURRENCE	RECOMMENDATIONS
Swainson's Hawk <i>Buteo swainsoni</i>	ST, BCC	Summer resident in the region. Nests in stands with few trees in juniper-sage flats, riparian areas and in oak savannah. Requires adjacent suitable foraging areas such as grasslands, or alfalfa or grains fields supporting rodent populations.	<b>No Potential.</b> This species is not known from coastal California.	No further action necessary.
American Peregrine Falcon <i>Falco peregrinus anatum</i>	FT, SE	Resident and winter visitor to region. Occurs near wetlands, lakes, rivers, or other water; on cliffs, banks, dunes, mounds; also, human-made structures. Nest consists of a scrape on a depression or ledge in an open site.	<b>Unlikely.</b> The vicinity only contains poor quality nesting habitat for this species, however, this species may forage in the vicinity.	No further action necessary.
Prairie Falcon <i>Falco mexicanus</i>	BCC, DFG:WL	Resident and winter visitor to region. Inhabits dry, open terrain, either level or hilly. Breeding sites located on cliffs. Forages far afield, even to marshlands and ocean shores.	<b>Unlikely.</b> The vicinity only contains poor quality nesting habitat for this species, however, this species may forage in the vicinity.	No further action necessary.
California Clapper Rail <i>Rallus longirostris obsoletus</i>	FE, SE, CFP	Found in tidal salt marsh and brackish marshes supporting emergent vegetation, upland refugia, and incised tidal channels. Restricted to the San Francisco Bay estuary.	<b>Not Present.</b> The vicinity is outside of this species' range.	No further action necessary.
California Black Rail <i>Laterallus jamaicensis coturniculus</i>	ST, CFP, BCC	Occurs in tidal salt marsh with dense stands of pickleweed as well as freshwater to brackish marshes.	<b>Not Present.</b> Typical nesting and foraging habitat is not located in the vicinity.	No further action necessary.
Western Snowy Plover <i>Charadrius alexandrinus nivosus</i>	FT, SSC, BCC, RP	Federal listing applies only to the Pacific coastal population. Year-round resident on sandy beaches, salt pond levees and shores of large alkali lakes. Requires sandy, gravelly or friable soils for nesting.	<b>Unlikely.</b> This species is not reported to nest near the vicinity.	Conduct work outside the nesting season (April 1 to September 1) or conduct pre-construction survey on beach area.

SPECIES	STATUS*	HABITAT	POTENTIAL FOR OCCURRENCE	RECOMMENDATIONS
Caspian Tern <i>Sterna caspia</i>	BCC	Summer resident in the region. Nests in small colonies inland and along the coast, usually on small islands and sandbars.	<b>Unlikely.</b> The vicinity does not contain typical breeding habitat for this species. This species may forage off shore of the vicinity.	No further action necessary.
Elegant Tern <i>Sterna elegans</i>	BCC, DFG:WL	Post-breeding dispersent to coastal habitats in the region; not known to nest north of San Diego County. Forages for fish over open water.	<b>Unlikely.</b> This species does not breed in the vicinity. Occurs off shore of the vicinity.	No further action necessary.
California Least Tern <i>Sterna antillarum browni</i>	FE, SE	Summer resident in the region. Nests colonially along the coast from San Francisco bay south to northern Baja California. Colonial breeder on bare or sparsely vegetated, flat substrates: sand beaches, alkali flats, land fills, or paved areas.	<b>Unlikely.</b> The vicinity does not contain typical breeding habitat for this species. This species may forage off shore of the vicinity.	No further action necessary.
Black Oystercatcher <i>Haematopus bachmani</i>	BCC	Resident along rocky shorelines. Nests are small bowls or depressions close to the shore.	<b>Unlikely.</b> While this species may forage off-shore of the vicinity, the tidal inundation and ocean spray along the granitic shelf do not support suitable breeding habitat.	No further action necessary.
Long-billed Curlew <i>Numenius americanus</i>	BCC, DFG:WL	Breeds in upland shortgrass prairies and wet meadows in northeastern California. Winter visitor to the region, occurring in grasslands and shores.	<b>Unlikely.</b> This species may forage along the shore of the vicinity but does not breed here.	No further action necessary.
Short-tailed Albatross <i>Diomedea albatrus</i>	FE	Nests on Japanese islands. Very rare winter visitor to offshore California waters.	<b>Not Present.</b> This species occurs within the region only rarely, and is found well offshore.	No further action necessary.
Xantu's Murrelet <i>Synthliboramphus hypoleucus</i>	SSC	Generally rare post-breeding dispersent to the region. Pelagic, breeding on offshore islands in rock crevices or under bushes. Does not breed north of the Channel Islands.	<b>Unlikely.</b> This species may forage off shore of the vicinity but does not breed here.	No further action necessary.



SPECIES	STATUS*	HABITAT	POTENTIAL FOR OCCURRENCE	RECOMMENDATIONS
Cassin's Auklet <i>Ptychoramphus aleuticus</i>	SSC, BCC	Pelagic species, nesting colonially in burrows on coastal and offshore islands.	<b>Unlikely.</b> This species may forage off shore of the vicinity but does not breed here.	No further action necessary.
Marbled Murrelet <i>Brachyramphus marmoratus</i>	FT, SE	Breed in old-growth redwood stands containing platform-like branches along the coast. Winters in coastal waters.	<b>Unlikely.</b> This species may forage off shore of the vicinity but does not breed here.	No further action necessary.
Tufted Puffin <i>Fratercula cirrhata</i>	BCC	Pelagic; nests along the coast on islands, islets, or (rarely) mainland cliffs. Typically winters well offshore.	<b>Unlikely.</b> This species may forage off shore of the vicinity but does not breed here.	No further action necessary.
Western Burrowing Owl <i>Athene cunicularia hypugea</i>	SSC, BCC	Open, dry annual or perennial grasslands, deserts and scrub lands characterized by low-growing vegetation. Subterranean nester, dependent upon burrowing mammals, most notably, the California ground squirrel.	<b>Unlikely.</b> No ground squirrel burrows and more likely further inland.	No further action necessary.
Long-eared Owl <i>Asio otus</i>	SCC	Generally uncommon resident and winter visitor in the region. Found in a variety of woodland types. Requires adjacent open land productive of mice and the presence of old nests of crows, hawks, or magpies for breeding.	<b>Unlikely.</b> The vicinity does not provide any typical habitat for this species.	No further action necessary.
Short-eared Owl <i>Asio flammeus</i>	SSC	Resident and mostly winter visitor to the region. Found in swamp lands, both fresh and salt; lowland meadows; irrigated alfalfa fields. Tule patches/tall grass needed for nesting/daytime seclusion. Nests on dry ground in depression concealed in vegetation.	<b>Unlikely.</b> The vicinity does not provide any typical habitat for this species.	No further action necessary.

SPECIES	STATUS*	HABITAT	POTENTIAL FOR OCCURRENCE	RECOMMENDATIONS
Vaux's Swift <i>Chaetura vauxi</i>	SSC	Summer resident. Forages high in the air over most terrain and habitats but prefers rivers/lakes. Requires large hollow trees for nesting, usually within old-growth forest.	<b>Unlikely.</b> There are no recent breeding records within the vicinity of the vicinity, and the vicinity does not offer old-growth forest habitat.	No further action necessary.
Black Swift <i>Cypseloides niger</i>	SSC	Patchily-distributed summer resident in California, occurring in coastal and forested habitats. Nest sites are usually associated with waterfalls.	<b>Unlikely.</b> Typical nesting habitat is not located in the vicinity.	No further action necessary.
Rufous Hummingbird <i>Selasphorus rufus</i>	BCC	Migrant and uncommon summer resident in California. Found in a wide variety of habitats that provide nectar-producing flowers. Typically breeds north of the region.	<b>Unlikely.</b> No known breeding records in San Mateo County; probably occurs within the vicinity during migration.	No further action necessary.
Lewis's Woodpecker <i>Melanerpes lewis</i>	BCC	Uncommon winter resident occurring on open oak savannahs, broken deciduous and coniferous habitats.	<b>Unlikely.</b> Typical nesting habitat is not present in the vicinity.	No further action necessary.
Olive-sided Flycatcher <i>Contopus cooperi</i>	SSC, BCC	Conifer forests where tall trees overlook canyons, meadows, lakes or other open terrain	<b>Unlikely.</b> Typical nesting habitat is not present in the vicinity.	No further action necessary.
Little Willow Flycatcher <i>Empidonax traillii brewsteri</i>	SE	Most numerous where extensive thickets of low, dense willows edge on wet meadows, ponds, or backwaters. Winter migrant.	<b>Unlikely.</b> No known occurrences in San Mateo County, may occur as a migrant.	No further action necessary.
Purple Martin <i>Progne subis</i>	SSC	Inhabits woodlands, low elevation coniferous forest. Nest in snags, old woodpecker cavities and human-made structures.	<b>Unlikely.</b> No known colonies near the vicinity.	No further action necessary.



SPECIES	STATUS*	HABITAT	POTENTIAL FOR OCCURRENCE	RECOMMENDATIONS
Bank Swallow <i>Riparia riparia</i>	ST	Migrant in riparian and other lowland habitats in western California. Nests in riparian areas with vertical cliffs and bands with fine-textured or sandy soils in which to nest.	<b>Unlikely.</b> No known colonies near the vicinity.	No further action necessary.
Loggerhead Shrike <i>Lanius ludovicianus</i>	SSC, BCC	Prefers open habitats with scattered shrubs, trees, posts, or other perches. Eats mostly large insects.	<b>Unlikely.</b> Typical nesting habitat is not present in the vicinity.	No further action necessary.
San Francisco (Saltmarsh) Common Yellowthroat <i>Geothlypis trichas sinuosa</i>	SSC, BCC	Resident of San Francisco bay region fresh and salt water marshes. Requires thick, continuous cover down to water surface for foraging, tall grasses, tule patches, willows for nesting.	<b>Unlikely.</b> Typical nesting habitat is not present in the vicinity.	No further action necessary.
Yellow-breasted Chat <i>Icteria virens</i>	SSC	Summer resident; inhabits riparian thickets of willow and other brushy tangles near watercourses. Nests in low, dense riparian thickets consisting of willow, blackberry, wild grape	<b>Unlikely.</b> Typical nesting habitat is not present in the vicinity.	No further action necessary.
Yellow Warbler <i>Dendroica petechia</i>	SSC	Summer resident in the region. Nests in riparian stands of aspens, sycamores and alders with a dense understory of willows. Also nests in montane shrubbery in open conifer forests.	<b>Unlikely.</b> Typical nesting habitat is not present in the vicinity.	No further action necessary.
Grasshopper Sparrow <i>Ammodramus savannarum</i>	SSC	Frequents dense tall, dry or well-drained grasslands, especially native grasslands with mixed grasses and forbs for foraging and nesting. Nests on ground at base of overhanging clumps of vegetation.	<b>Unlikely.</b> Typical nesting habitat is not present in the vicinity.	No further action necessary.

SPECIES	STATUS*	HABITAT	POTENTIAL FOR OCCURRENCE	RECOMMENDATIONS
Bryant's Savannah Sparrow <i>Passerculus sandwichensis alaudinus</i>	SSC	Year-round resident of tidal marshes and grasslands in coastal fog belt. Breeds from April through July.	<b>Unlikely.</b> Typical nesting habitat is not present in the vicinity.	No further action necessary.
Alameda Song Sparrow <i>Melospiza melodia pusillula</i>	SSC, BCC	Year-round resident in tidal-influenced marshes along the eastern and southern portions of San Francisco Bay.	<b>Not Present.</b> The vicinity is outside of this species' recognized range.	No further action necessary.
Tricolored Blackbird <i>Agelaius tricolor</i>	SSC, BCC	Usually nests over or near freshwater in dense cattails, tules, or thickets of willow, blackberry, wild rose or other tall herbs. Nesting area must be large enough to support about 50 pairs.	<b>Unlikely.</b> Typical nesting habitat is not present in the vicinity.	No further action necessary.

SPECIES	STATUS*	HABITAT	POTENTIAL FOR OCCURRENCE	RECOMMENDATIONS
<b>Reptiles and Amphibians</b>				
Western Pond Turtle <i>Actinemys marmorata</i>	SSC	Occurs in perennial ponds, lakes, rivers and streams with suitable basking habitat (mud banks, mats of floating vegetation, partially submerged logs) and submerged shelter.	<b>Unlikely.</b> This species is not known near the vicinity and is more typical of perennial pond environments with basking sites.	No further action necessary.
California Horned Lizard <i>Phrynosoma coronatum frontale</i>	SSC	Frequents a wide variety of habitats, most common in lowlands along sandy washes with scattered low bushes. Needs open areas for sunning, bushes for cover and abundant supply of ants and other insects.	<b>Unlikely.</b> Not known near the vicinity.	No further action necessary.
San Francisco Garter Snake <i>Thamnophis sirtalis tetrataenia</i>	FE, SE, CFP, RP	vicinity of freshwater marshes, ponds and slow moving streams in San Mateo County and extreme northern Santa Cruz County. Prefers dense vegetative cover and water depths of at least one foot. Upland areas near water are important habitat features.	<b>Unlikely.</b> No freshwater marsh habitat is present within or adjacent to the vicinity.	No further action necessary.
Western Spade-foot toad <i>Scaphiopus hammondi</i>	SSC	Occurs primarily in grasslands but occasionally populates valley-foothill hardwood woodlands. Feed on insects, worms, and other invertebrates.	<b>Unlikely.</b> Not known near the vicinity.	No further action necessary.
California Tiger Salamander <i>Ambystoma californiense</i>	FT, SSC	Need underground refuges, especially ground squirrel burrows and vernal pools or other seasonal water sources for breeding.	<b>Unlikely.</b> There are no nearby occurrences to the vicinity.	No further action necessary.
California Red-legged Frog <i>Rana draytonii</i>	FT, SSC	Associated with quiet perennial to intermittent ponds, stream pools and wetlands. Prefers shorelines with extensive vegetation. Documented to disperse through upland habitats after rains.	<b>Unlikely.</b> No freshwater marsh habitat is present within or adjacent to the vicinity.	No further action necessary.



SPECIES	STATUS*	HABITAT	POTENTIAL FOR OCCURRENCE	RECOMMENDATIONS
<b>Fish</b>				
River Lamprey <i>Lampetra ayresi</i>	SSC	Lower Sacramento River, San Joaquin River and Russian River. May occur in coastal streams north of San Francisco Bay. Adults need clean, gravelly riffles, Ammocetes need sandy backwaters or stream edges, good water quality and temps < 25 degrees C.	<b>No Potential.</b> The vicinity does not contain suitable habitat for this species.	No further action necessary.
Green Sturgeon <i>Acipenser medirostris</i>	FT	Spawn in the Sacramento River and the Klamath River. Spawn at temperatures between 8-14 degrees C. Preferred spawning substrate is large cobble, but can range from clean sand to bedrock.	<b>No Potential.</b> The vicinity does not contain suitable habitat for this species, however, it may forage off shore.	No further action necessary.
Pacific Herring <i>Clupea pallasii</i>	None	Pacific herring is a coastal marine fish that uses large estuaries for spawning and early rearing habitat.	<b>No Potential.</b> The vicinity does not contain suitable habitat for this species, however, it may forage off shore.	No further action necessary.
Tidewater Goby <i>Eucyclogobius newberryi</i>	FE	Brackish water habitats along the California coast from Agua Hedionda Lagoon, San Diego County to the mouth of the Smith River. Found in shallow lagoons and lower stream reaches, they need fairly still but not stagnant water and high oxygen levels.	<b>No Potential.</b> The vicinity does not contain suitable habitat for this species, however, it may forage off shore.	No further action necessary.
Steelhead - Central Valley ESU <i>Oncorhynchus mykiss irideus</i>	FT	Occurs from the Russian River south to Soquel Creek and Pajaro River. Also in San Francisco and San Pablo Bay Basins. Populations in the Sacramento and San Joaquin Rivers and their tributaries. Adults migrate upstream to spawn in cool, clear, well-oxygenated streams. Juveniles remain in fresh water for 1 or more years before migrating downstream to the ocean.	<b>No Potential.</b> The vicinity does not contain suitable habitat for this species, however, it may forage off shore.	No further action necessary.

SPECIES	STATUS*	HABITAT	POTENTIAL FOR OCCURRENCE	RECOMMENDATIONS
Steelhead, Central California Coast ESU <i>Oncorhynchus mykiss</i>	FT	Occurs from the Russian River south to Soquel Creek and Pajaro River. Also in San Francisco and San Pablo Bay Basins. Adults migrate upstream to spawn in cool, clear, well-oxygenated streams. Juveniles remain in fresh water for 1 or more years before migrating downstream to the ocean.	<b>No Potential.</b> The vicinity does not contain suitable habitat for this species, however, it may forage off shore.	No further action necessary.
Winter-run Chinook Salmon, Sacramento River <i>Oncorhynchus tshawytscha</i>	FE	Occurs in the Sacramento River below Keswick Dam. Spawns in the Sacramento River but not in tributary streams. Requires clean, cold water over gravel beds with water temperatures between 6 and 14 degrees C for spawning. Adults migrate upstream to spawn in cool, clear, well-oxygenated streams. Juveniles typically migrate to the ocean soon after emergence from the gravel.	<b>No Potential.</b> The vicinity does not contain suitable habitat for this species, however, it may forage off shore.	No further action necessary.
Central Valley Spring-run Chinook Salmon <i>Oncorhynchus tshawytscha</i>	FT	Populations spawning in the Sacramento and San Joaquin Rivers and their tributaries. Adults migrate upstream to spawn in cool, clear, well-oxygenated streams. Juveniles remain in fresh water for 1 or more years before migrating downstream to the ocean.	<b>No Potential.</b> The vicinity does not contain suitable habitat for this species, however, it may forage off shore.	No further action necessary.
Central Valley Fall- and Late Fall-run Chinook Salmon ESU <i>Oncorhynchus tshawytscha</i>	NMFS SC	Populations spawning in the Sacramento and San Joaquin Rivers and their tributaries. Adults migrate upstream to spawn in cool, clear, well-oxygenated streams. Juveniles remain in fresh water for 1 or more years before migrating downstream to the ocean.	<b>No Potential.</b> The vicinity does not contain suitable habitat for this species, however, it may forage off shore.	No further action necessary.

SPECIES	STATUS*	HABITAT	POTENTIAL FOR OCCURRENCE	RECOMMENDATIONS
Coho Salmon - Central CA Coast ESU <i>Oncorhynchus kisutch</i>	FE, SE	Federal listing includes populations between Punta Gorda and San Lorenzo River. State listing includes populations south of San Francisco Bay only. Occurs inland and in coastal marine waters. Requires beds of loose, silt-free, coarse gravel for spawning. Also needs cover, cool water and sufficient dissolved oxygen.	<b>No Potential.</b> The vicinity does not contain suitable habitat for this species, however, it may forage off shore.	No further action necessary.
<b>Invertebrates</b>				
white abalone <i>Haliotis sorenseni</i>	FE	White abalone is the first marine invertebrate to be listed under the ESA and are reported to be most abundant between 25-30 m (80-100 ft depth).	<b>Not Present.</b> The vicinity is outside of the known range for this species.	No further action necessary.
black abalone <i>Haliotis cracherodii</i>	FE, NMF5 SC	Ranges from Cabo San Lucas to Mendocino County. Found in intertidal and shallow subtidal areas.	<b>Unlikely.</b> Suitable habitat for this species does not occur within the vicinity.	No further surveys or mitigation measures are necessary.
Bay checkerspot butterfly <i>Euphydryas editha bayensis</i>	FT	Restricted to native grasslands on outcrops of serpentine soil in the vicinity of San Francisco Bay. <i>Plantago erecta</i> is the primary host plant; <i>Orthocarpus densiflorus</i> and <i>O. purpurascens</i> are the secondary host plants.	<b>Unlikely.</b> No known occurrences near the vicinity.	No further surveys or mitigation measures are necessary.
monarch butterfly <i>Danaus plexippus</i>	winter roosts monitored by CDFG	Winter roost sites located in wind-protected tree groves (Eucalyptus, Monterey pine, cypress), with nectar and water sources nearby.	<b>Unlikely.</b> Potential roost trees in the vicinity are fully exposed to the elements.	No further surveys or mitigation measures are necessary.
Myrtle's silverspot <i>Speyeria zerene myrteae</i>	FE	Foggy, coastal dunes and hills of the Point Reyes Peninsula.	<b>Not Present.</b> Extirpated from San Mateo County.	No further surveys or mitigation measures are necessary.



SPECIES	STATUS*	HABITAT	POTENTIAL FOR OCCURRENCE	RECOMMENDATIONS
callippe silverspot butterfly <i>Speyeria callippe callippe</i>	FE	Hostplant is <i>Viola pedunculata</i> , most adults found on east facing slopes, males congregate on hilltops in search of females.	<b>Unlikely.</b> No known occurrences near the vicinity.	No further actions are recommended for this species.
Lange's metalmark butterfly <i>Apodemia mormo langei</i>	FE, SSI, RP	Inhabits stabilized dunes along the San Joaquin River. Endemic to Antioch Dunes, Contra Costa County. Primary host plant is <i>Eriogonum nudum</i> var. <i>auriculatum</i> ; feeds on nectar of other wildflowers, as well as host plant.	<b>Unlikely.</b> No known occurrences in San Mateo County.	No further actions are recommended for this species.
San Bruno elfin butterfly <i>Callophrys mossii bayensis</i>	FE	Colonies are located on steep, north-facing slopes in the vicinity of San Bruno mountain, San Mateo County. Larval host plant is <i>Sedum spathulifolium</i> .	<b>Unlikely.</b> No known occurrences near the vicinity.	No further actions are recommended for this species.
mission blue butterfly <i>Plebejus icarioides missionensis</i>	FE	Grasslands of the San Francisco Peninsula. Host plants are three species of lupine, of which <i>Lupinus albifrons</i> is preferred.	<b>Unlikely.</b> No known occurrences near the vicinity.	No further surveys or mitigation measures are necessary.
conservancy fairy shrimp <i>Branchinecta conservatio</i>	FE	Endemic to the grasslands of the northern two-thirds of the central valley. Inhabit astatic pools located in swales formed by old, braided alluvium; filled by winter/spring rains, last until June.	<b>No Potential.</b> The vicinity does not contain suitable habitat for this species.	No further actions are recommended for this species.
vernal pool fairy shrimp <i>Branchinecta lynchi</i>	FT	Endemic to the grasslands of the central valley, central coast mountain, and south coast mountains. Inhabit small, clear-water sandstone-depression pools and grassed swales, earth slump, or basalt-flow depression pools.	<b>No Potential.</b> The vicinity does not contain suitable habitat for this species.	No further actions are recommended for this species.

SPECIES	STATUS*	HABITAT	POTENTIAL FOR OCCURRENCE	RECOMMENDATIONS
longhorn fairy shrimp <i>Branchinecta longiantenna</i>	FE, SSI, RP	Endemic to the eastern margin of the central coast mountains in seasonally astatic grassland vernal pools. Inhabit small, clear-water depressions in sandstone and clear-to-turbid clay/grass-bottomed pools in shallow swales.	<b>No Potential.</b> The vicinity does not contain suitable habitat for this species.	No further actions are recommended for this species.
vernal pool tadpole shrimp <i>Lepidurus packardii</i>	FE	Pools commonly found in grass bottomed swales of unplowed grasslands. Some pools are mud-bottomed and highly turbid.	<b>No Potential.</b> The vicinity does not contain suitable habitat for this species.	No further actions are recommended for this species.
San Francisco tree lupine moth <i>Grapholita edwardsiana</i>	SMC LCP	Occurs only on sandy northern peninsula sites. Tree lupine ( <i>Lupinus arboreus</i> ) host the larvae of this species. This species is addressed in the San Mateo County LCP.	<b>Unlikely.</b> No tree lupine observed near the vicinity.	No further actions are recommended for this species.
California brackish water snail <i>Tryonia imitator</i>	SMC LCP	Occurs in brackish water, such as Pescadero Marsh.	<b>No Potential.</b> The vicinity does not contain suitable habitat for this species.	No further actions are recommended for this species.
globose dune beetle <i>Coelus globosus</i>	SMC LCP	Inhabits California's coastal dune system.	<b>Unlikely.</b> No dune habitat within the vicinity.	No further actions are recommended for this species.
<b>Plants</b>				
<i>Acanthomintha duttonii</i> San Mateo thorn mint	List 1B	Chaparral, valley and foothill grassland, often on serpentine soils. 50-300m. Blooms April-June.	<b>Unlikely.</b> Suitable habitat is not present within the vicinity.	No additional surveys or mitigation measures are recommended.
<i>Allium peninsulare</i> var. <i>franciscanum</i> Franciscan onion	List 1B	Cismontane woodland, valley and foothill grassland, found on clay, volcanic and often serpentine soils. 100-300m elevation. Blooms May-June.	<b>Unlikely.</b> Suitable soils do not occur within the vicinity.	No additional surveys or mitigation measures are recommended.



SPECIES	STATUS*	HABITAT	POTENTIAL FOR OCCURRENCE	RECOMMENDATIONS
<i>Amsinckia lunaris</i> bent-flowered fiddleneck	List 1B	Coastal bluff scrub, cismontane woodland, valley and foothill grassland. 3-500m. Blooms March-June.	<b>Unlikely.</b> A small area of disturbed coastal bluff scrub occurs within the vicinity.	No additional surveys or mitigation measures are recommended
<i>Arctostaphylos andersonii</i> Santa Cruz manzanita	List 1B	Broadleaved upland forest, chaparral, and North Coast coniferous forest. Found on open sites and redwood forest at elevations of 60-700m. Known only from Santa Cruz Mountains. Blooms Nov-April.	<b>Not Present.</b> Suitable habitat for this species is not present within the vicinity. Species found only in the Santa Cruz mountains.	No additional surveys or mitigation measures are recommended.
<i>Arctostaphylos hookeri</i> ssp. <i>ravenii</i> Presidio manzanita	List 1B	Chaparral, coastal prairie, coastal scrub in serpentine soil. 45-215m. Blooms February-March.	<b>Unlikely.</b> Suitable habitat is not present. Serpentine soil does not occur within the vicinity.	No additional surveys or mitigation measures are recommended.
<i>Arctostaphylos imbricata</i> San Bruno Mountain manzanita	List 1B	Chaparral, coastal scrub. 275-370m. Blooms February-May.	<b>Potential</b> Suitable areas of coastal scrub habitat are present within the vicinity.	Survey any undisturbed areas where staging or grading may occur and avoid where feasible.
<i>Arctostaphylos montaraensis</i> Montara manzanita	List 1B	Chaparral, coastal scrub. 150-500m. Blooms January-March.	<b>Potential.</b> Suitable areas of coastal scrub habitat are present within the vicinity;	Survey any undisturbed areas where staging or grading may occur and avoid where feasible.
<i>Arctostaphylos pacifica</i> Pacific manzanita	List 1B	Chaparral and coastal scrub. 330-330m. Blooms February- April.	<b>Potential.</b> Suitable areas of coastal scrub habitat are present within the vicinity;	Survey any undisturbed areas where staging or grading may occur and avoid where feasible.
<i>Arctostaphylos regismontana</i> Kings Mountain manzanita	List 1B	Broadleaved upland forest, chaparral, north coast coniferous forest, often on granite or sandstone soils. 305-730 meters. Blooms Jan-April.	<b>Potential.</b> Suitable habitat not present within the vicinity.	Survey any undisturbed areas where staging or grading may occur and avoid where feasible.

SPECIES	STATUS*	HABITAT	POTENTIAL FOR OCCURRENCE	RECOMMENDATIONS
<i>Astragalus pycnostachyus</i> var. <i>pycnostachyus</i> coastal marsh milk-vetch	List 1B	Coastal dunes (mesic) and marshes and swamps (coastal salt, stream-sides). Found at elevations of 0-30m. Blooms April-Oct.	<b>Unlikely.</b> No suitable habitat occurs within the vicinity.	No additional surveys or mitigation measures are recommended.
<i>Astragalus tener</i> var. <i>alkali milk-vetch</i>	List 1B	Alkali playa, valley and foothill grassland, vernal pools. Low ground, alkali flats, and flooded lands. 1-170m. Blooms March-June.	<b>Unlikely.</b> No suitable habitat occurs within the vicinity.	No additional surveys or mitigation measures are recommended.
<i>Centromadia parryi</i> ssp. <i>parryi</i> pappose tarplant	List 1B	Coastal prairie, meadows and seeps, coastal salt marsh, valley and foothill grassland. Vernal mesic, often alkaline sites. 2-420m. Blooms May-November.	<b>Unlikely.</b> Suitable habitat is not present within the vicinity.	No additional surveys or mitigation measures are recommended.
<i>Chorizanthe cuspidata</i> var. <i>cuspidata</i> San Francisco Bay spineflower	List 1B	Coastal bluff scrub, coastal dunes, coastal prairie, coastal scrub, often on sandy soils. 3-215 meters. Blooms April-July.	<b>Potential.</b> Suitable areas of coastal scrub habitat are present within the vicinity; however, this habitat has been disturbed by the 2008 landslide.	Survey any undisturbed areas where staging or grading may occur and avoid where feasible.
<i>Chorizanthe robusta</i> var. <i>robusta</i> robust spineflower	List 1B	Chaparral, cismontane woodland, coastal dunes, coastal scrub, in sandy or gravelly soil. 3-300m. Blooms April-September.	<b>Unlikely.</b> Suitable habitat is not present within the vicinity.	No additional surveys or mitigation measures are recommended.
<i>Cirsium andrewsii</i> Franciscan thistle	List 1B	Broad leafed upland forest, coastal bluff scrub, coastal prairie, coastal scrub/mesic, sometimes serpentine. 0-135m. Blooms March-July.	<b>Potential.</b> Suitable coastal bluff scrub habitat is present within the vicinity, although no serpentine soils occur on-site.	.Survey any undisturbed areas where staging or grading may occur and avoid where feasible.
<i>Cirsium fontinale</i> var. <i>fontinale</i> fountain thistle	FE, SE, List 1B	Chaparral, cismontane woodlands, valley and foothill grasslands, often in serpentine seeps. 90-175m elevation. Blooms June-Oct.	<b>Unlikely.</b> Suitable habitat is not present on-site. Serpentine soil does not occur within the vicinity.	No additional surveys or mitigation measures are recommended.



SPECIES	STATUS*	HABITAT	POTENTIAL FOR OCCURRENCE	RECOMMENDATIONS
<i>Cirsium occidentale</i> <i>var. compactum</i> compact cobwebby thistle	List 1B	Chaparral, coastal dunes, coastal prairie, coastal scrub. 5-150m. Blooms April- June.	<b>Unlikely.</b> Suitable habitat is not present within the vicinity.	No additional surveys or mitigation measures are recommended
<i>Collinsia multicolor</i> San Francisco collinsia	List 1B	Closed cone coniferous forest, coastal scrub, sometimes on serpentine soils. 30-250m elevation. Blooms March-May.	<b>Unlikely.</b> No serpentine soils occur on-site.	No additional surveys or mitigation measures are recommended
<i>Cordylanthus</i> <i>maritimus</i> ssp. <i>palustris</i> Point Reyes bird's- beak	List 1B	Coastal salt marshes and swamps. 1- 10 m. Blooms June- October.	<b>Unlikely.</b> No suitable habitat occurs within the vicinity.	No additional surveys or mitigation measures are recommended.
<i>Dirca occidentalis</i> western leatherwood	List 1B	Broadleafed upland forest, closed-cone coniferous forest, chaparral, cismontane woodland, North Coast coniferous forest, riparian forest, riparian woodland/mesic. 50-395m. Blooms January - April.	<b>Unlikely.</b> Suitable riparian habitat is not present within the vicinity.	No additional surveys or mitigation measures are recommended.
<i>Equisetum palustre</i> marsh horsetail	List 3	Marshes and swamps. 45-150m.	<b>Unlikely.</b> No suitable habitat occurs within the vicinity.	No additional surveys or mitigation measures are recommended.
<i>Eriophyllum latilobum</i> San Mateo wooly sunflower	FE, SE, List 1B	Cismontane woodland, often on roadcuts, on and off of serpentine, 45-150 m elevation. Blooms May-June.	<b>Unlikely.</b> No suitable habitat occurs within the vicinity.	No additional surveys or mitigation measures are recommended.
<i>Fritillaria biflora</i> var. <i>ineziana</i> Hillsborough chocolate lily	List 1B	Cismontane woodland, valley and foothill grassland in serpentine soils. 150-150m. Blooms March-April.	<b>Unlikely.</b> No suitable habitat or serpentine soils occur within the vicinity.	No additional surveys or mitigation measures are recommended.
<i>Fritillaria lanceolata</i> var. <i>tristulis</i> Mission bells	List 1B	Coastal bluff scrub, coastal prairie, coastal scrub. 15-150m. Blooms February-May.	<b>Potential.</b> A small amount of coastal bluff scrub habitat is present within the vicinity.	No further surveys or mitigation measures are necessary.

SPECIES	STATUS*	HABITAT	POTENTIAL FOR OCCURRENCE	RECOMMENDATIONS
<i>Fritillaria liliacea</i> fragrant fritillary	List 1B	Coastal scrub, valley and foothill grassland, coastal prairie. Often on serpentine; various soils reported though usually clay, in grassland. 3-410m. Blooms February-April.	<b>Unlikely.</b> No serpentine soils occur within the vicinity.	No additional surveys or mitigation measures are recommended
<i>Gilia capitata</i> ssp. <i>chamissonis</i> dune gilia	List 1B	Coastal dunes and coastal scrub. 2-200m. Blooms April-July.	<b>Unlikely.</b> No suitable habitat occurs within the vicinity.	No additional surveys or mitigation measures are recommended
<i>Grindelia hirsutula</i> var. <i>maritima</i> San Francisco gumplant	List 1B	Coastal scrub, coastal bluff scrub, and valley and foothill grassland. Found on sandy or serpentine slopes and sea bluffs at elevations of 15-400m. Blooms June-September.	<b>Potential.</b> Suitable coastal bluff scrub habitat is present within the vicinity.	Survey any undisturbed areas where staging or grading may occur and avoid where feasible.
<i>Helianthella castanea</i> Diablo helianthella	List 1B	Broadleaved upland forest, chaparral, cismontane woodland, coastal scrub, riparian woodland, valley and foothill grassland. 60-1300m. Blooms March-June.	<b>Unlikely.</b> Suitable habitat is not present within the vicinity.	No additional surveys or mitigation measures are recommended
<i>Hemizonia congesta</i> ssp. <i>congesta</i> hayfield tarplant	List 1B	Valley and foothill grassland and sometimes along roadsides. 20-560m. Blooms April-November.	<b>Unlikely.</b> No suitable habitat or serpentine soils occur within the vicinity.	No additional surveys or mitigation measures are recommended.
<i>Hesperevax</i> <i>sparsiflora</i> var. <i>brevifolia</i> shortleaf dwarf cudweed	List 2	Coastal bluff scrub in sandy soils and coastal dunes. 0-215m. Blooms March-June.	<b>Potential.</b> Suitable coastal bluff scrub habitat is present within the vicinity.	Survey any undisturbed areas where staging or grading may occur and avoid where feasible.
<i>Hesperolinon</i> <i>congestum</i> Marin western flax	FT, ST, List 1B	Chaparral and valley and foothill grassland on serpentine soils. 5- 370 m. Blooms April- July.	<b>Unlikely</b> Serpentine soil does not occur within the vicinity.	No additional surveys or mitigation measures are recommended.



SPECIES	STATUS*	HABITAT	POTENTIAL FOR OCCURRENCE	RECOMMENDATIONS
<i>Horkelia cuneata</i> ssp. sericea Kellogg's horkelia	List 1B	Closed cone coniferous forest, maritime chaparral, and openings in coastal scrub habitat on gravelly or sandy soils. 10-200m elevation. Blooms April-September.	<b>Unlikely.</b> Suitable habitat is not present within the vicinity.	No additional surveys or mitigation measures are recommended.
<i>Horkelia marinensis</i> Point Reyes horkelia	List 1B	Coastal dunes, coastal prairie, coastal scrub. 10-150m. Blooms May-September.	<b>Unlikely.</b> Suitable habitat is not present within the vicinity.	No additional surveys or mitigation measures are recommended.
<i>Layia carnosa</i> beach layia	FE, SE, List 1B	Coastal dunes and coastal scrub. 0-60m. Blooms March -July.	<b>Unlikely.</b> Suitable coastal scrub habitat is not present within the vicinity.	No additional surveys or mitigation measures are recommended.
<i>Leptosiphon croceus</i> coast yellow leptosiphon	List 1B	Coastal bluff scrub and coastal prairie. 10-150m elevation. Blooms April-May.	<b>Potential.</b> Suitable coastal bluff scrub habitat is present within the vicinity.	Survey any undisturbed areas where staging or grading may occur and avoid where feasible.
<i>Leptosiphon rosaceus</i> rose leptosiphon	List 1B	Coastal bluff scrub. 0-100m elevation. Blooms April-July.	<b>Potential.</b> Suitable coastal bluff scrub habitat is present within the vicinity.	.Survey any undisturbed areas where staging or grading may occur and avoid where feasible.
<i>Lessingia arachnoidea</i> Crystal Springs lessingia	List 1B	Cismontane woodland, coastal scrub, serpentine soils in valley and foothill grasslands, often roadsides. 60-200m elevation Blooms July-Oct.	<b>Unlikely.</b> No suitable habitat or serpentine soils occur within the vicinity.	No additional surveys or mitigation measures are recommended.
<i>Lessingia germanorum</i> San Francisco lessingia	List 1B	Coastal scrub, possibly in remnant dune habitat. 25-90m. Blooms July-November.	<b>Unlikely.</b> Suitable habitat is not present within the vicinity.	No additional surveys or mitigation measures are recommended.
<i>Lessingia hololeuca</i> woolly-headed lessingia	List 3	Broadleaved upland forest, coastal scrub, lower montane coniferous forest, valley and foothill grassland on clay and serpentine. 15-305m. Blooms June-October.	<b>Unlikely.</b> Suitable habitat is not present within the vicinity.	No additional surveys or mitigation measures are recommended.

SPECIES	STATUS*	HABITAT	POTENTIAL FOR OCCURRENCE	RECOMMENDATIONS
<i>Lilium maritimum</i> coast lily	List 1B	Broadleaved upland forest, closed cone coniferous forest, coastal prairie, coastal scrub, marshes and swamps, North Coast coniferous forest, sometimes on roadsides. 90-550m. Blooms May-August.	<b>Unlikely.</b> Suitable habitat is not present within the vicinity.	No additional surveys or mitigation measures are recommended.
<i>Lupinus arboreus</i> var. <i>eximius</i> San Mateo tree lupine	List 3	Coastal prairie, mesic meadows and seeps, freshwater marshes and swamps, and vernal pools. 1-140m elevation. Blooms March-May.	<b>Unlikely.</b> No suitable habitat occurs within the vicinity.	No additional surveys or mitigation measures are recommended.
<i>Malacothamnus</i> <i>aboriginum</i> Gray bushmallow	List 1B	Chaparral, cismontane woodland on rocky soil, often in burned areas. 150-1700m. Blooms April-October.	<b>Unlikely.</b> No suitable habitat occurs within the vicinity.	No additional surveys or mitigation measures are recommended.
<i>Malacothamnus</i> <i>arcuatus</i> arcuate bush mallow	List 1B	This evergreen shrub is found in chaparral at elevations of 15-355m. Blooms April-Sept.	<b>Unlikely.</b> No suitable habitat occurs within the vicinity.	No additional surveys or mitigation measures are recommended.
<i>Malacothamnus</i> <i>davidsonii</i> Davidson's bushmallow	List 1B	Chaparral, cismontane woodland, coastal scrub and riparian woodland. 185-855m. Blooms June-July.	<b>Unlikely.</b> Suitable habitat is not present within the vicinity.	No additional surveys or mitigation measures are recommended.
<i>Malacothamnus hallii</i> Hall's bush mallow	List 1B	Chaparral. Some populations on serpentine. 10-550m. Blooms May-September.	<b>Unlikely.</b> No suitable habitat occurs within the vicinity.	No additional surveys or mitigation measures are recommended.
<i>Monolopia gracilens</i> woodland monolopia	List 1B	Openings in broadleaved upland forest, chaparral, cismontane woodland and north coast coniferous forest. In serpentine soils on valley and foothill grasslands. 100-200m. Blooms March-July.	<b>Unlikely.</b> No suitable habitat occurs within the vicinity.	No additional surveys or mitigation measures are recommended.
<i>Pedicularis dudleyi</i> Dudley's lousewort	List 1B	Maritime chaparral, cismontane woodland, North Coast coniferous forest, valley and foothill grassland. 60-900m elevation. Blooms April-June.	<b>Unlikely.</b> No suitable habitat occurs within the vicinity.	No additional surveys or mitigation measures are recommended.



SPECIES	STATUS*	HABITAT	POTENTIAL FOR OCCURRENCE	RECOMMENDATIONS
<i>Pentachaeta bellidiflora</i> white-rayed pentachaeta	FE, SE, List 1B	Valley and foothill grassland (often on serpentine soil) and cismontane woodland. 35- 620 m. Blooms March- May.	<b>Unlikely.</b> No suitable habitat occurs within the vicinity.	No additional surveys or mitigation measures are recommended.
<i>Plagiobothrys chorisianus</i> var. <i>chorisianus</i> Choris' popcornflower	List 1B	Chaparral, coastal prairie, and coastal scrub. Found in mesic areas at elevations of 15-100m. Blooms March-June.	<b>Unlikely.</b> Suitable habitat is not present within the vicinity.	No additional surveys or mitigation measures are recommended.
<i>Polemonium carneum</i> Oregon polemonium	List 1B	Coastal prairie, coastal scrub, lower montane coniferous forest. 0-1930m. Blooms April-September	<b>Unlikely.</b> Suitable habitat is not present within the vicinity.	No additional surveys or mitigation measures are recommended.
<i>Potentilla hickmanii</i> Hickman's cinquefoil	List 1B	Coastal bluff scrub, closed-cone coniferous forest, meadows and seeps, freshwater marshes and swamps. 10-135m. Blooms April-August.	<b>Potential.</b> Suitable coastal bluff scrub habitat is present within the vicinity.	Survey any undisturbed areas where staging or grading may occur and avoid where feasible.
<i>Sanicula maritima</i> adobe sanicle	SR, List 1B	Chaparral, coastal prairie, meadows and seeps, valley and foothill grasslands on serpentine soils. 30-240m. Blooms February- May.	<b>Unlikely.</b> No suitable habitat occurs within the vicinity.	No additional surveys or mitigation measures are recommended.
<i>Silene verecunda</i> ssp. <i>verecunda</i> San Francisco campion	List 1B	Coastal bluff scrub, chaparral, coastal prairie, coastal scrub, valley and foothill grassland (sandy). 30-645m elevation. Blooms March to June (August).	<b>Potential.</b> Suitable coastal bluff scrub habitat is present within the vicinity.	Survey any undisturbed areas where staging or grading may occur and avoid where feasible..
<i>Suaeda californica</i> California seablite	FE, List 1B	Coastal salt marshes and swamps. 0- 15 m. Blooms July- October.	<b>Unlikely.</b> No suitable habitat occurs within the vicinity.	No additional surveys or mitigation measures are recommended.
<i>Trifolium depauperatum</i> var. <i>hydrophilum</i> saline clover	List 1B	Marshes and swamps, valley and foothill grassland, vernal pools. 0-300m. Blooms April-June.	<b>Unlikely.</b> No suitable habitat occurs within the vicinity.	No additional surveys or mitigation measures are recommended.

SPECIES	STATUS*	HABITAT	POTENTIAL FOR OCCURRENCE	RECOMMENDATIONS
<i>Triphysaria floribunda</i> San Francisco owl's clover	List 1B	Coastal prairie, coastal scrub, valley and foothill grassland usually on serpentinite soils. 10-160m. Blooms April-June.	<b>Unlikely.</b> No suitable serpentinite soils occur on-site.	No additional surveys or mitigation measures are recommended.
<i>Triquetrella californica</i> coastal triquetrella	List 1B	Coastal bluff scrub and coastal scrub. 10- 100m. Moss.	<b>Potential.</b> Suitable coastal bluff scrub habitat is present within the vicinity.	Survey any undisturbed areas where staging or grading may occur and avoid where feasible.



SPECIES	STATUS*	HABITAT	POTENTIAL FOR OCCURRENCE	RECOMMENDATIONS
<b>* Key to status codes:</b>				
EFH		Essential Fish Habitat		
FE		Federal Endangered		
FT		Federal Threatened		
FD		Federal De-listed		
FC		Federal Candidate		
BCC		U.S. Fish & Wildlife Service (USFWS) Birds of Conservation Concern		
NMFS SC		National Marine Fisheries Service Species of Concern		
RP		Sensitive species included in a USFWS Recovery Plan or Draft Recovery Plan		
SE		State Endangered		
ST		State Threatened		
SMC LCP		San Mateo County Local Coastal Program species		
SR		State Rare		
SSC		California Department of Fish and Game (CDFG) Species of Special Concern		
CFP		CDFG Fully Protected Animal		
SSI		CDFG Special Status Invertebrates		
WBWG		Western Bat Working Group High Priority species		
List 1A		California Native Plant Society (CNPS) List 1A: Plants presumed extinct in California.		
List 1B		California Native Plant Society (CNPS) List 1B: Plants rare, threatened or endangered in California and elsewhere		
List 2		CNPS List 2: Plants rare, threatened, or endangered in California, but more common elsewhere		
List 3		CNPS List 3: Plants about which CNPS needs more information (a review list)		
<b>Potential species occurrence definitions:</b>				
				<ul style="list-style-type: none"> <li><u>Potential.</u> Some of the habitat components meeting the species requirements are present, and/or only some of the habitat on or adjacent to the site is unsuitable. The species has a moderate probability of being found on the site.</li> <li><u>Unlikely.</u> Few of the habitat components meeting the species requirements are present, and/or the majority of habitat on and adjacent to the site is unsuitable or of very poor quality. The species has a low probability of being found on the site.</li> <li><u>No Potential.</u> Habitat on and adjacent to the site is clearly unsuitable for the species requirements (foraging, breeding, cover, substrate, elevation, hydrology, plant community, site history, disturbance regime).</li> <li><u>Not Present.</u> Species was not observed during protocol-level plant surveys performed during the appropriate blooming period.</li> </ul>

August 14, 2013

Kerry Burke  
34 Amesport  
Half Moon Bay, CA 94019

Re: Geotechnical Report for Removal of Fill Slope: 20165 Cabrillo Highway,  
San Gregorio.  
Sigma Prime Geosciences Job No. 13-135

Dear Ms. Burke:

As per our agreement, we have performed a geotechnical study to evaluate the geotechnical issues related to the removal of the fill slope at the address referenced above. The accompanying report summarizes the results of our evaluation. We have also prepared a site restoration plan that shows the proposed work in detail. If you have any questions concerning our study, please call at 650-728-3590.

Yours,

Sigma Prime Geosciences, Inc.



Charles M. Kissick, P.E.



## 1. INTRODUCTION

### 1.1 PROJECT DESCRIPTION

Approximately 7200 cubic yards of soil and rock were excavated at the top of the sea cliff and the material was pushed over the side of the cliff to form a wedge of uncompacted fill that is about 50 feet tall. The work was done without permits and must be removed and replaced in its original location.

The existing slope is resting at its angle of repose and is marginally stable. Tension cracks have formed at the top of the slope. The material is dry and uncompacted. We expect the slope to fail once it becomes wetter and heavier with the first rains of the rainy season. In addition, the larger waves that occur in the fall are likely to erode the toe of the slope. Therefore, it must be removed as soon as possible.

There are no buildings near the site that may be affected by the work.

### 1.2 PROPOSED SCOPE OF WORK

The fill material on the beach will be excavated and put back in place at the top of the sea cliff. In order to achieve this, two long-reach excavators are proposed, and possibly a drag line. The material will be spread in 1-foot lifts and track walked to achieve nominal compaction of between 85 and 89 percent. The relatively low compaction is desirable, as the natural permeability and the soil's ability to support natural vegetation is necessary. The steepest fill slopes will be not steeper than 2:1. Once the project is finished, the site should match the original site conditions as closely as possible.

## 2. FINDINGS

### 2.1 SITE CONDITIONS

Before the unpermitted work was done, the site was dominated by a sea cliff that was vertical to an elevation of about 40 feet. Above the vertical slope, the cliff face is inclined at about 1.5:1 to an elevation of about 370 feet. There are level benches scattered throughout the area that break up the 1.5:1 slope. The soil and rock that was excavated to create the fill slope (the borrow area) came from an adjacent level bench at an elevation of about 120 feet.

The borrow area is on a large landslide that appears, based on aerial photographs, to have activated during the 1990s. The landslide encompasses a small "nose" in the sea cliff and covers an area of about 450 feet from north to



south, and up to 200 feet from east to west. The toe of the landslide is at beach level.

## 2.2 SITE SUBSURFACE CONDITIONS

The exposed surface of the borrow area revealed highly weathered and fractured Pliocene age Lobitos mudstone member of the Purisima formation. The mudstone dips into the slope at less than 10 degrees. The weathering and fracturing of the mudstone made is very easy to excavated and resulted in the material degrading to gravelly clay during earthwork. The topsoil in the area is very poorly developed and less than 1 foot thick.

The fill slope is comprised of the Lobitos mudstone that has degraded to a gravelly clay. As mentioned above, the fill was not compacted and is very loose/soft.

The vertical cliff has formed in the Pliocene age San Gregorio Sandstone member of the Purisima formation.

Springs at the contact between the two rock formations are common. Also, there appears to be a spring at a higher elevation within the Lobitos mudstone. This spring is buried by the new fill and is slowly saturating the fill.

## 3. **CONCLUSIONS AND RECOMMENDATIONS**

The only real geotechnical issue related to this project is slope stability, as there are no structures on or near the project. It should be noted that the site is in an actively eroding and degrading environment. The Lobitos mudstone is continuously raveling and creating talus slopes on the beach. The winter waves routinely remove the talus and the process repeats every year. Small landslides are also common. The large landslide described above has made the face of the sea cliff in the project area more prone to degradation.

The fact that the project area is in an undeveloped area that is best maintained in its natural state, the proposed project will not be meant to create maximum, long-term slope stability, as would normally be the case in a project that involves conventional site improvements, such as houses and roads. However, slope stability is an issue during construction to protect the safety of the workers.

During construction, we will be on site to consult with the earthwork contactor to make sure that the equipment stays in place. The first concern is the presence of the saturated fill soil where the buried spring is. We recommend that the earthwork contractor remove the saturated soil, install a subdrain system consisting of perforated pipes and gravel, and replacing dry fill to create a stable, safe surface. As the work proceeds, the drainage system may need adjusting.



As the fill slope is removed, the vertical cliff should become exposed again. Above the vertical cliff, the slope will be inclined at 2:1 with fills and cuts, as needed. The slopes will then be vegetated and protected from erosion. We recommend relatively light compaction of less than 90 percent to promote vegetation growth, and to allow the slope to degrade at close to the same rate as the surrounding natural slopes. A small degree of slope instability is acceptable. It is our opinion that a 2:1 slope with the prescribed compaction will be relatively stable and will not fail on a large scale.

During final construction, we will consult with the earthwork contractor to create a drainage system to handle the spring that is currently buried. We will create a system that does not concentrate the seepage and mimics the natural seepage pattern as closely as possible. Because the spring is currently buried, we do not know the full aerial extent of the spring and can not come up with a specific plan at this time.



*This is  
copy from  
Emergency CDP/GICX  
PWA 2013-00341*

California Coastal Commission

## **EMERGENCY COASTAL DEVELOPMENT PERMIT**

**Emergency CDP G-2-13-0212**

**(Bluff Restoration seaward of 20165 Cabrillo Highway)**

**Issue Date: September 12, 2013**

**Page 1 of 5**

This emergency coastal development permit (ECDP) authorizes temporary emergency development designed to restore a bluff area that was graded without benefit of a coastal development permit (CDP).

ECDP Permittees (CHHMB LLC) and the Permittees' representative (Kerry Burke) submitted materials regarding the need and justification for the proposed temporary emergency development. Commission staff (including the Commission's senior coastal engineer, Lesley Ewing, and senior coastal geologist, Mark Johnsson) have reviewed the relevant materials and have concluded that the bluff has been destabilized due to unpermitted grading, that the graded bluff materials (approximately 7,200 cubic yards) represent a risk to water quality and bluff integrity, and that in a storm event, the mostly unconsolidated fine-grained clay bluff materials could exacerbate all of these issues. The proposed restoration work is necessary to restore the bluff back to its original configuration as soon as possible. In short, the proposed emergency development is necessary to prevent the potential water quality and bluff stability impacts at this site.

Therefore, the Commission's Executive Director hereby finds that: (a) an emergency exists that requires action more quickly than permitted by the procedures for regular CDPs; (b) that the proposed emergency development can and will be completed within 30 days (unless extended for good cause); and (c) public comment on the proposed emergency development has been reviewed to the degree time has allowed. The emergency development is hereby approved, subject to the conditions listed in this ECDP.

### **Conditions of Approval**

1. The enclosed ECDP acceptance form must be signed by all Permittees and owners of property where the temporary emergency development authorized by this ECDP is located and returned to the California Coastal Commission's North Central Coast District Office within 15 days of the date of this permit (i.e., by September 27, 2013). This ECDP is not valid unless and until the acceptance form has been received in the North Central Coast District Office.
2. Only that temporary emergency development specifically described in this ECDP is authorized. Any additional and/or different emergency and/or other development requires separate authorization from the Executive Director and/or the Coastal Commission.

Madeline Cavalieri, North Central Coast District Manager for Charles Lester, Executive Director

**Attachment F**



**Emergency CDP G-2-13-0212**  
**(Bluff Restoration seaward of 20165 Cabrillo Highway)**

**Issue Date: September 12, 2013**

**Page 2 of 5**

3. The temporary emergency development authorized by this ECDP must be completed within 30 days of the date of this permit (i.e., by October 12, 2013) unless extended for good cause by the Executive Director.
4. The emergency development authorized by this ECDP is only temporary, and shall be removed if it is not authorized by a regular CDP. Within 60 days of the date of this permit (i.e., by November 11, 2013), the Permittee shall submit a complete application for a regular CDP to retain the emergency development. Any such application shall include photos showing the project site before the emergency, during emergency project construction activities, and after the work authorized by this ECDP is complete. Otherwise, the temporary emergency development shall be removed in its entirety within 150 days of the date of this permit (i.e., by February 9, 2013) and all areas affected by it restored to their prior development condition unless before that time the California Coastal Commission has issued a regular CDP for the development authorized by this ECDP. The deadlines in this condition may be extended for good cause by the Executive Director.
5. In exercising this ECDP, the Permittee agrees to hold the California Coastal Commission harmless from any liabilities for damage to public or private properties or personal injury that may result from the temporary emergency development project.
6. This ECDP does not obviate the need to obtain necessary authorizations and/or permits from other agencies (e.g., San Mateo County, California State Lands Commission, Monterey Bay National Marine Sanctuary, etc.) for the temporary emergency development. The Permittee shall submit to the Executive Director copies of all such authorizations and/or permits upon their issuance.
7. The temporary emergency development shall be limited in scale and scope to that identified in the plans titled "Restoration Plan" dated prepared August 8, 2013 and dated received by the Coastal Commission August 16, 2013, with the following additions and conditions:
  - a. The restored fill slope shall be keyed, cut, and benched into the underlying formation at the base of the bluff in a way designed to minimize landform alteration and result in a final bluff configuration that closely approximates the bluff configuration present before the unpermitted grading.
  - b. The bluff shall be revegetated with non-invasive and native plants that replicate vegetation patterns in surrounding bluffs. All non-native and invasive species in the project area (e.g., iceplant) shall be removed.
  - c. All piping installed for drainage purposes shall be removed within 30 days of the project completion. This date may be extended for good cause by the Executive Director, provided the intent of the extension is to ensure that the final reconfigured bluff restores the bluff back to its pre-unpermitted grading configuration.
8. A licensed civil engineer or geologist with experience in coastal bluffs and processes shall oversee all construction activities and shall ensure that all temporary emergency development is limited to the least amount necessary to abate the emergency.



**California Coastal Commission**

**Attachment F**



**Emergency CDP G-2-13-0212**  
**(Bluff Restoration seaward of 20165 Cabrillo Highway)**

**Issue Date: September 12, 2013**

**Page 3 of 5**

9. All emergency construction activities shall limit impacts to the beach and the Pacific Ocean to the maximum extent feasible including by, at a minimum, adhering to the following construction requirements, which may be adjusted by the Executive Director if such adjustments: (1) are deemed necessary due to extenuating circumstances; and (2) will not adversely impact coastal resources:
  - a. All work shall take place during daylight hours. Lighting of the beach area is prohibited.
  - b. Construction work and equipment operations shall not be conducted seaward of the highest tide line unless tidal waters have receded from the authorized work areas.
  - c. Grading of intertidal areas is prohibited.
  - d. Any construction materials and equipment delivered to the beach area shall be delivered by rubber-tired construction vehicles. When transiting on the beach, all such vehicles shall remain as high on the upper beach as possible and avoid contact with ocean waters and intertidal areas.
  - e. All construction materials and equipment placed on the beach during daylight construction hours shall be stored beyond the reach of tidal waters. All construction materials and equipment shall be removed in their entirety from the beach area by sunset each day that work occurs. The only exceptions shall be for: (1) erosion and sediment controls (e.g., a silt fence at the base of the construction area) as necessary to contain rock and/or sediments in the construction area, where such controls are placed as far inland as possible, and are minimized in their extent; and (2) storage of larger materials beyond the reach of tidal waters for which moving the materials each day would be extremely difficult. Any larger materials intended to be left on the beach area overnight must be approved in advance by the Executive Director, and shall be subject to a contingency plan for moving said materials in the event of tidal/wave surge reaching them.
  - f. All construction areas shall be minimized and demarked by temporary fencing designed to allow through public access and protect public safety to the maximum extent feasible. Construction (including but not limited to construction activities, and materials and/or equipment storage) is prohibited outside of the defined construction, staging, and storage areas.
  - g. The construction site shall maintain good construction site housekeeping controls and procedures (e.g., clean up all leaks, drips, and other spills immediately; keep materials covered and out of the rain (including covering exposed piles of soil and wastes); dispose of all wastes properly, place trash receptacles on site for that purpose, and cover open trash receptacles during wet weather; remove all construction debris from the beach; etc.).
  - h. All construction activities that result in discharge of materials, polluted runoff, or wastes to the beach or the adjacent marine environment are prohibited. Equipment washing, refueling, and/or servicing shall not take place on the beach. Any erosion and sediment controls used shall be in place prior to the commencement of construction as well as at the end of each work day.
  - i. All beach areas and all shoreline access points impacted by construction activities shall be restored to their pre-construction condition or better within three days of completion of





**Emergency CDP G-2-13-0212**  
**(Bluff Restoration seaward of 20165 Cabrillo Highway)**

**Issue Date: September 12, 2013**

**Page 4 of 5**

construction. Any beach sand in the area that is impacted by construction shall be filtered as necessary to remove all construction debris.

- j. All exposed slopes and soil surfaces in and/or adjacent to the construction area shall be stabilized with erosion control native seed mix, jute netting, straw mulch, or other applicable best management practices (for example, those identified in the California Storm Water Best Management Practice Handbooks (March, 1993)). The use of non-native invasive species (such as ice-plant) is prohibited.
  - k. All contractors shall insure that work crews are carefully briefed on the importance of observing the construction precautions given the sensitive work environment. Construction contracts shall contain appropriate penalty provisions sufficient to offset the cost of retrieval/clean-up of foreign materials not properly contained and/or remediation to ensure compliance with this ECDP otherwise.
  - l. The Permittee shall notify planning staff of the Coastal Commission's North Central Coast District Office immediately upon completion of construction and required beach-area restoration activities. If planning staff should identify additional reasonable measures necessary to restore the beach and beach access points, such measures shall be implemented immediately.
10. Copies of this ECDP shall be maintained in a conspicuous location at the construction job site at all times, and such copies shall be available for public review on request. All persons involved with the construction shall be briefed on the content and meaning of this ECDP, and the public review requirements applicable to it, prior to commencement of construction.
  11. A construction coordinator shall be designated to be contacted during construction should questions arise regarding the construction (in case of both regular inquiries and emergencies), and their contact information (i.e., address, phone numbers, etc.) including, at a minimum, a telephone number that will be made available 24 hours a day for the duration of construction, shall be conspicuously posted at the job site where such contact information is readily visible from public viewing areas, along with indication that the construction coordinator should be contacted in the case of questions regarding the construction (in case of both regular inquiries and emergencies). The construction coordinator shall record the name, phone number, and nature of all complaints received regarding the construction, and shall investigate complaints and take remedial action, if necessary, within 24 hours of receipt of the complaint or inquiry.
  12. Within 30 days of completion of the construction authorized by this ECDP, the Permittee shall submit site plans and cross sections prepared by a licensed civil engineer with experience in coastal structures and processes clearly identifying all development completed under this emergency authorization (comparing the bluff's pre-graded condition to both the emergency condition and to the post-work condition), and a narrative description of all emergency development activities undertaken pursuant to this emergency authorization.
  13. This ECDP shall not constitute a waiver of any public rights which may exist on the property. The Permittee shall not use this ECDP as evidence of a waiver of any public rights which may exist on



**Emergency CDP G-2-13-0212**  
**(Bluff Restoration seaward of 20165 Cabrillo Highway)**

**Issue Date: September 12, 2013**

**Page 5 of 5**

the property.

14. Failure to comply with the conditions of this approval may result in enforcement action under the provisions of Chapter 9 of the Coastal Act.
15. The issuance of this ECDP does not constitute admission as to the legality of any development undertaken on the subject site without a CDP and shall be without prejudice to the California Coastal Commission's ability to pursue any remedy under Chapter 9 of the Coastal Act.

As noted in Condition 4 above, the emergency development carried out under this ECDP is at the Permittee's risk and is considered to be temporary work done in an emergency situation to abate an emergency. If the Permittee wishes to have the emergency development become permanent development, a regular CDP must be obtained. A regular CDP is subject to all of the provisions of the California Coastal Act and may be conditioned or denied accordingly.

If you have any questions about the provisions of this ECDP, please contact the Commission's North Central Coast District Office at 45 Fremont Street, Suite 2000, San Francisco, CA 94105, (415) 904-5260.



**California Coastal Commission**

**Attachment F**





County of San Mateo

## Planning & Building Department

455 County Center, 2nd Floor  
Redwood City, California 94063  
650/363-4161 Fax: 650/363-4849

Mail Drop PLN122  
plngbldg@smcgov.org  
[www.co.sanmateo.ca.us/planning](http://www.co.sanmateo.ca.us/planning)

October 7, 2013

Ms. Kerry L. Burke  
Burke Land Use  
34 Amesport Landing  
Half Moon Bay, CA 94019

PROJECT FILE

Dear Ms. Burke:

SUBJECT: Grading Permit Exemption  
Coastal Bluff Repair at 20165 Cabrillo Highway, San Gregorio  
APN 081-060-070; County File No. PLN 2013-00341

Staff has reviewed your application for a grading permit exemption to perform earthwork involving 7,200 cubic yards (c.y.) of balanced cut and fill associated with the restoration of a coastal bluff damaged from illegal grading (VIO 2013-00120). Per Section 8600 of the County's Grading and Land Clearing Regulations, the original grading work is subject to a grading permit. This permit exemption does not authorize the original grading work, but only the proposed restoration work, which has been determined to be exempt from permit under Section 8603.10 (Emergency Work) because project implementation is necessary to protect the safety of beach visitors from further bluff collapse and erosion.

The restoration project involves approximately 39,750 square feet of land disturbance over the 21.45-acre project site. The project has been reviewed and recommended for approval by the Planning and Building Department's Geotechnical Engineer and the Department of Public Works.

On July 23, 2013, the County received a complaint regarding illegal grading at the bluff site and opened a violation case (VIO 2013-00120). The applicant was directed to apply for an Emergency Coastal Development Permit Exemption and a Grading Permit Exemption for restoration work and submitted the applications to the County on August 8, 2013. The County sent a project referral to the California Coastal Commission (CCC) on August 12, 2013. On August 21, 2013, the CCC recommended a consolidated Coastal Development Permit for the project under the permitting authority of the CCC. On August 30, 2013, the County authorized the CCC to act as lead agency for the Coastal Development Permit. The CCC issued an Emergency Coastal Development Permit (CDP G-2-13-0212) for the project on September 12, 2013.

Attachment G



This grading permit exemption is for the above-described grading only and is valid for the term of Emergency Coastal Development Permit (G-2-13-0212). Should there be a conflict between the terms of this grading permit exemption and the terms of CDP G-2-13-0212, the terms of CDP G-2-13-0212 shall take precedence. Any other development will be subject to a separate review process.

Although the emergency restoration work is exempt from a Grading Permit, it must be executed in a manner that complies with water quality protection measures established by the Regional Water Quality Control Board. To this end, this exemption serves to inform you of the following requirements:

1. Prior to any land disturbance and throughout the grading operation, the property owner shall implement the approved erosion control plan, dated August 14, 2013, as prepared and signed by the engineer of record. The applicant shall implement the approved plan in its entirety including, but not limited to, erosion control measures, safety measures, and re-vegetation as described in the approved plan.
2. As required by Provision C.6 of the Municipal Regional Stormwater NPDES Permit, Order R2-2009-0074, NPDES Permit No. CAS612008, California Regional Water Quality Control Board, San Francisco Bay Region, October 14, 2009, the County is required to conduct inspections of the site as a "high priority site" monthly during the wet season until project completion. Per the County Planning and Building Department and the Department of Public Works' Stormwater Enforcement Response Plan (ERP), the project site has been determined to be a "high priority site," as the project involves work within a waterway.

*Charlie* (3) Within three (3) days of the completion of the project, the Project Geotechnical Engineer shall submit written certification to the Current Planning Section that all grading and drainage facilities have been completed in conformance with the approved plans and provide evidence of re-vegetation (e.g., photos of re-vegetated site) according to the approved plans.

4. It shall be the responsibility of the engineer of record to regularly inspect the erosion control measures for the duration of all grading remediation activities, especially after major storm events, and determine that they are functioning as designed and that proper maintenance is being performed. Deficiencies shall be immediately corrected, as determined by and implemented under the observation of the engineer of record.
5. Within sixty (60) days of the date of this permit exemption, the property owner shall apply for an After-the-Fact Grading Permit and pay for the performance of required CEQA analysis, for the original grading work performed without required permits.

For questions regarding this letter, please contact Camille Leung, Project Planner, at 650/363-1826.

Also, please take a few minutes and complete the online version of our Customer Survey which will help us to enhance our customer service. Thank you in advance for your time in providing valuable feedback.

The survey is available at: <http://www.co.sanmateo.ca.us/planning/survey>.

Sincerely,

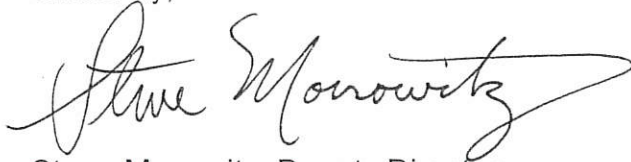
A handwritten signature in black ink that reads "Steve Monowitz". The signature is fluid and cursive, with a long horizontal stroke extending to the right.

Steve Monowitz, Deputy Director

SAM:CML:jlh – CMLX0690\_WJN.DOCX

cc: Jim Eggemeyer, Community Development Director  
County Counsel  
Planning and Building Department's Geotechnical Engineer  
CHHMB, Property Owner  
Dante Silvestri (via Email)  
Sigma Prime (via Email)  
State Public Lands Commission (via Email)  
California Coastal Commission



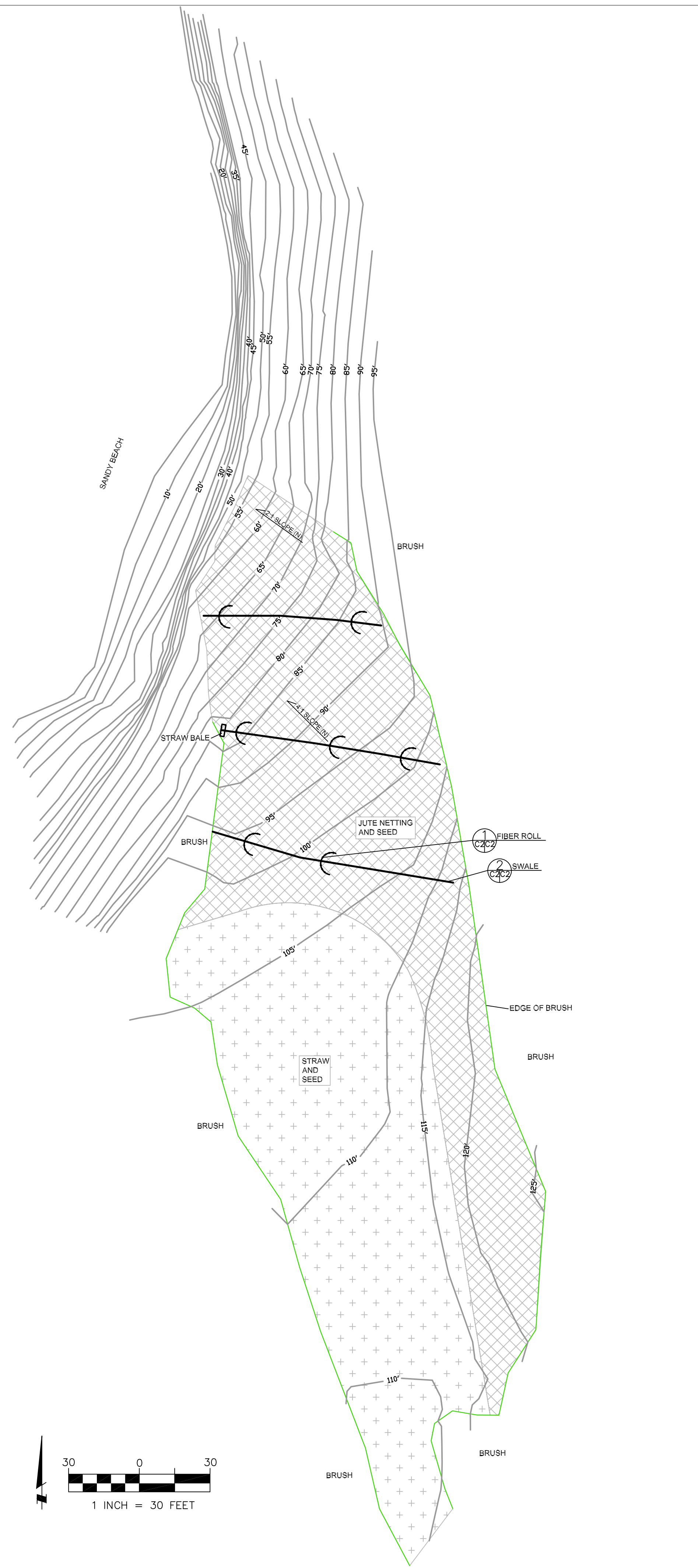

**LEGEND**

EXISTING 5' CONTOURS

**GENERAL NOTES**

1. APPROXIMATE AREA COVERED WITH STRAW OR JUTE NETTING = 40,000 SF.
2. THE PURPOSE OF THE PROJECT WAS TO RESTORE THE AREA TO THE PRE-CONSTRUCTION CONDITION. THE RESTORATION PROJECT CONSISTED OF MOVING SOIL FROM THE BEACH AND REPLACING IT ON TOP OF THE BLUFFS.
3. WORK DURATION EXPECTED WAS ABOUT 3 WEEKS FROM NOTICE TO PROCEED AND WAS COMPLETED BY OCTOBER 11.
4. PLANS PREPARED AT THE REQUEST OF:  
DANTE SILVESTRI AND KERRY BURKE, OWNER REPRESENTATIVES.
5. ORIGINAL SURVEY AND TOPOGRAPHY BY SIGMA PRIME, JULY 16, 2013.
6. ELEVATION DATUM ASSUMED.
7. THIS IS NOT A BOUNDARY SURVEY.
8. AS-BUILT CONDITIONS BASED ON OBSERVATIONS AND MEASUREMENTS MADE AFTER CONSTRUCTION. FINAL SITE VISIT ON NOVEMBER 8, 2013.
9. THERE WILL BE MONITORING AFTER STORM EVENTS, TO CHECK ON THE EFFECTIVENESS OF EROSION CONTROL MEASURES.

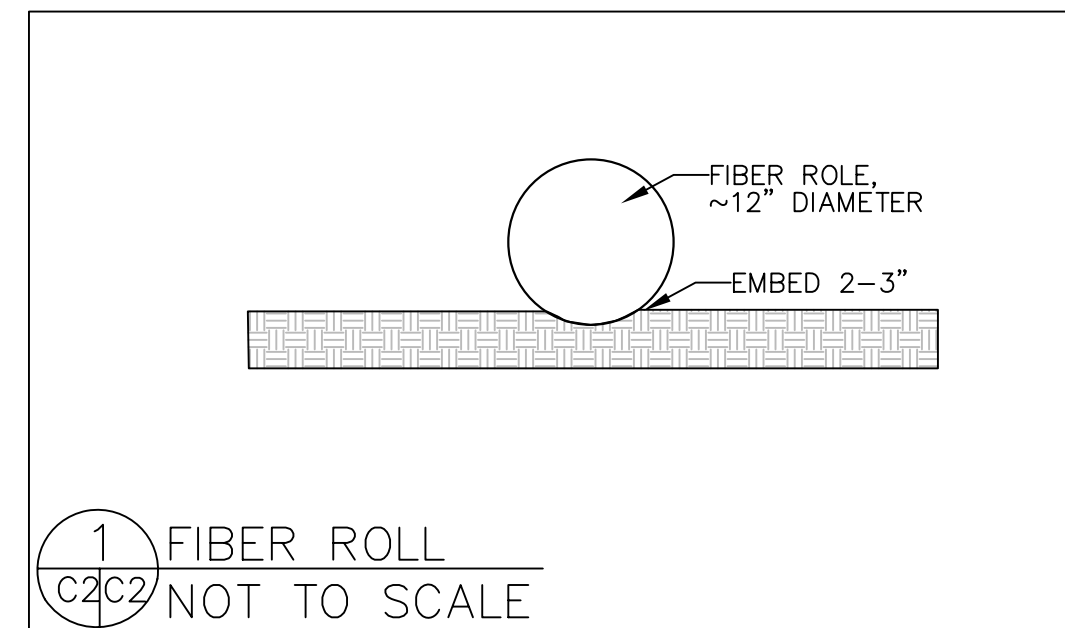
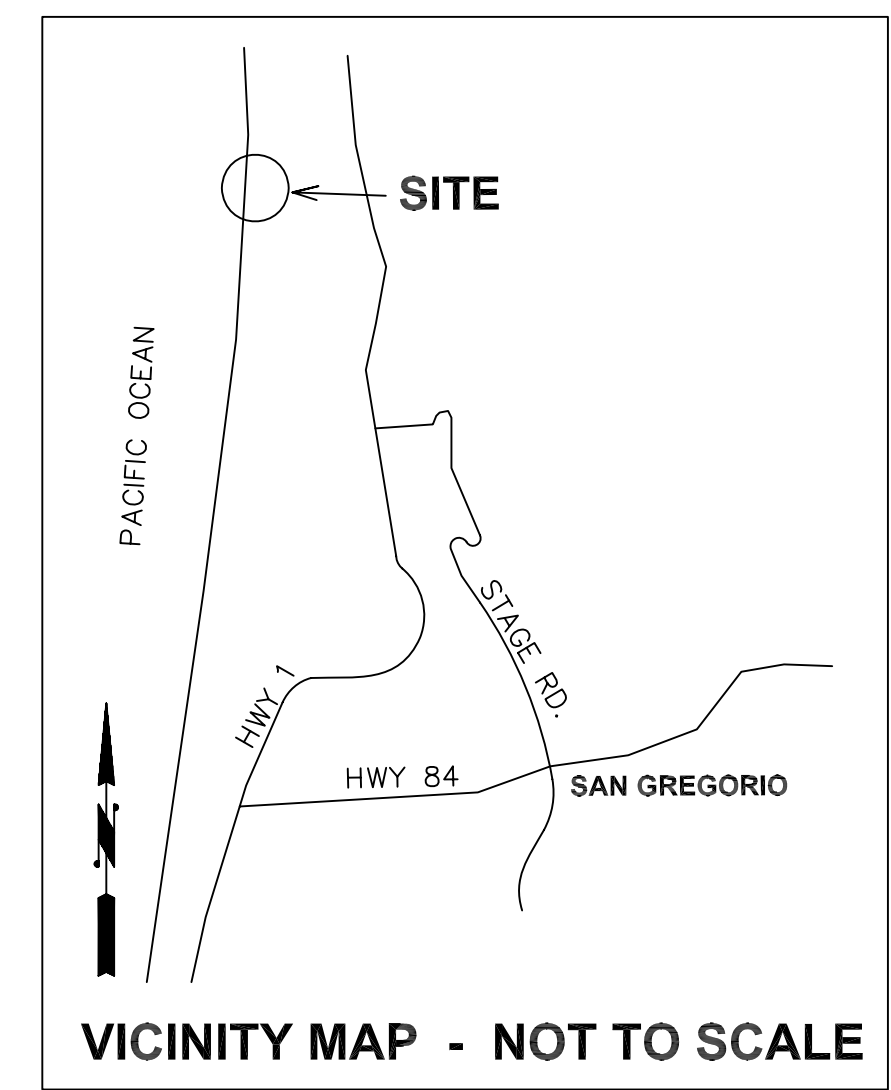

**EROSION CONTROL NOTES**

FIBER ROLL: INSTALLED AS SHOWN IN DETAIL 1

1. WORK WAS COMPLETED BY OCTOBER 11.
2. ALL EXPOSED SOIL HAS BEEN PROTECTED FROM EROSION AT ALL TIMES. SUCH PROTECTION CONSISTS OF JUTE NETTING AND SEEDING ON SLOPES AND STRAW AND SEED IN AREAS OF LEVEL GROUND.
3. SEED MIX CONSISTED OF GRASSES RECOMMENDED BY THE PROJECT BIOLOGIST AND APPROVED BY THE STATE.

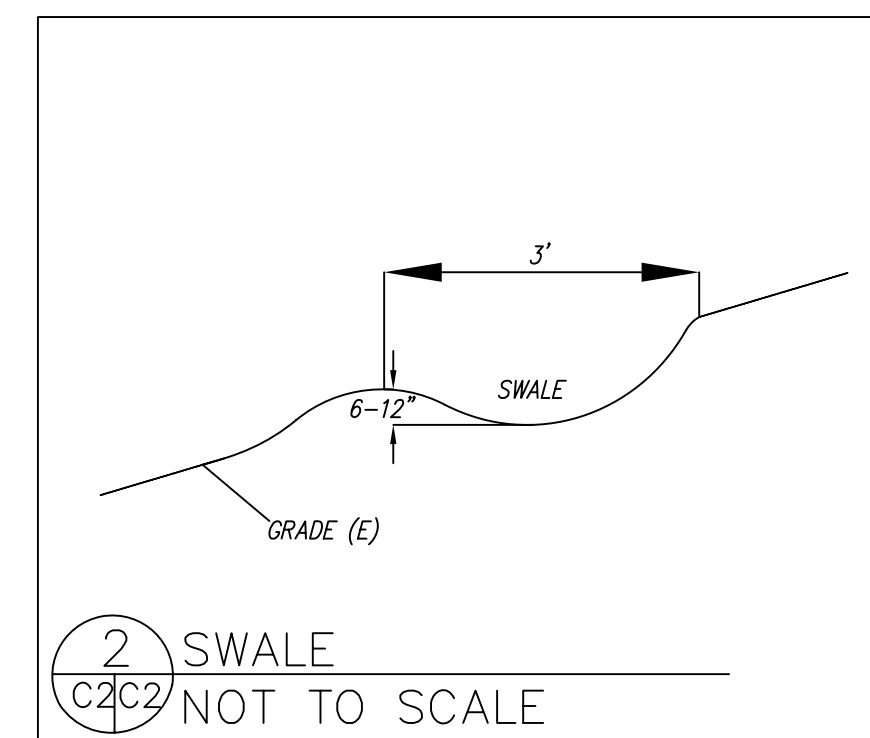

**SECTION AND DETAIL CONVENTION**

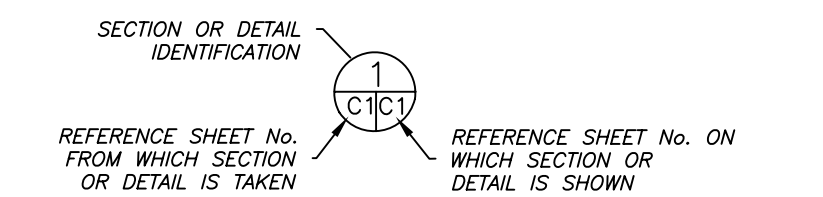

Sigma Prime Geosciences, Inc.  
SIGMA PRIME GEOSCIENCES, INC.  
111 VASSAR STREET  
HALF MOON BAY, CA 94019  
(650) 728-3590  
FAX 728-3593

DATE: 11-11-13	DRAWN BY: CMK	CHECKED BY: KLB	REV. DATE:	REV. DATE:	REV. DATE:
----------------	---------------	-----------------	------------	------------	------------

**AS-BUILT PLAN**  
CHMB PROPERTY  
20165 CABRILLO HIGHWAY  
SAN GREGORIO

SHEET  
C-2





Sigma Prime Geosciences, Inc.

November 12, 2013

Jay Mazzetta  
San Mateo County Building Department  
455 County Center, 2<sup>nd</sup> Floor  
Redwood City, CA 94063

Subject: Bluff Restoration Work at 20165 Cabrillo Highway  
Final Grading Letter

Sigma Prime Geosciences, Inc. made several site visits during the restoration work to observe the moving of the soil from the beach to the top of the bluff. The work was completed by October 12, 2013. The site has been restored to something very close to the site conditions before the original grading took place. Drainage has been restored to its natural patterns. The grading and drainage was done in conformance with our plans and recommendations and has our approval. A photograph of an area that has been covered with jute netting is attached.

If you have any questions or comments about this letter report, please call me at (650) 728-3590.

Yours,  
Sigma Prime Geosciences

  
Charles Kissick, P.E.



**RECEIVED**

NOV 12 2013

San Mateo County  
Planning Division

cc: Camille Leung  
Kerry Burke

111 Vassar Street, Half Moon Bay, CA 94019 (650) 728-3590 fax 728-3593

Attachment I





Attachment I



**CALIFORNIA COASTAL COMMISSION**

45 FREMONT, SUITE 2000  
SAN FRANCISCO, CA 94105-2 219  
VOICE (415) 904-5 260  
FAX (4 15) 904-5 400  
TDD (415) 597-5885



December 12, 2013

Kerry Burke  
34 Amesport Landing  
Half Moon Bay, CA 94019

**Subject: Filing Determination for Coastal Development Permit Application G-2-13-1111(Burke)**

Dear Ms. Burke:

Thank you for your submittal of Coastal Development Permit (CDP) application No. 2-13-111 seeking authorization for coastal bluff restoration activities that were conducted under Emergency Coastal Development Permit No. G-2-13-0212 (ECDP) at 20165 Cabrillo Highway, San Gregorio. As you are aware, the work conducted under the ECDP is considered temporary until you obtain a regular CDP. Commission staff has reviewed your submittal, which we received on November 13, 2013, and determined that the application is incomplete. Your CDP application cannot be deemed complete in accordance with the Commission's regulations (Title 14 CCR § 13056) until we receive pertinent information to facilitate our staff-review of the restoration work at the site. Please provide the materials and information requested below.

1. **Reduced-size Plans:** While you have provided two full-size copies of the As-built Plan, staff also requires a reduce-sized (8½" x 11" or 11"x17") copy of the plans. Please submit a hard copy and electronic file of the reduce-sized plans. Please also provide electronic files of photos that you submitted as part of the application.
2. **Appendix A:** While the Appendix A form is signed, no box is checked-off so as to disclose the status of campaign contributions. Please re-submit a complete form.
3. **Drainage:** Your CDP application includes a geotechnical report, "Geotechnical Report for removal of Fill Slope: 20165 Cabrillo Highway, San Gregorio", prepared by Sigma Prime Geosciences, dated August 14, 2013. The report's section "Conclusions and Recommendations" indicates a concern about saturated soil where the "buried spring is" and includes a recommendation that a sub-drain system be installed. It appears based upon Sigma's November 11, 2013 letter-report that a sub-drain system was temporarily installed during the work and then removed after completion, as required under the ECDP. Please submit a map for the site that shows the location of the buried spring

**Attachment J**



relative to the restoration area and describe how drainage of the site, on a permanent basis, is to be addressed.

Condition No. 7 of the ECDP requires that the "temporary emergency development shall be limited in scale and scope to that identified in the plans...prepared August 8, 2013". The Restoration Plan, dated August 8, 2013, and prepared by Sigma Prime Geosciences, Inc., indicates in its "Drainage Notes, 2." that the "final slopes are to be uniform and without swales in order to prevent concentrated surface runoff". The As-built Plan shows three swales. Please provide a narrative explanation of this modification to what was proposed for the restoration of the bluff back to its condition prior to the unpermitted grading, i.e., describe factors that contributed to the decision to construct the swales, as this is different than what is shown on the Restoration Plan.

4. **Revegetation:** WRA's August 7, 2013 biological report for the site indicates that a "more complete revegetation plan will be developed once the grading plan has been developed". The revegetation plan is to provide complete planting palettes, container sizes, quantities, seeding rates, planting times, and sources; along with an irrigation plan. The compliance letter dated November 11, 2013, prepared by Sigma Prime indicates that a native seed mix was used to re-seed the site, as recommended by WRA. Please submit:

- A revegetation plan for the restoration site that includes a plan for monitoring the progress and success of the revegetation. Identify what measures will be undertaken to ensure its success.
- Evidence/documentation of the species used at the site, such as receipts or an itemized list of the seed purchased from the source.

You may contact me if you have any questions or wish to discuss your application. I can be reached by telephone at (415) 904-5292 or in writing at the address shown above in the letterhead.

Sincerely,



Renée Ananda  
Coastal Program Analyst  
North Central Coast District

Cc: Steve Monowitz, San Mateo County  
Camille Leung, San Mateo County

Attachment J

**CALIFORNIA COASTAL COMMISSION**

45 FREMONT, SUITE 2000  
SAN FRANCISCO, CA 94105-2 219  
VOICE (415) 904-5 260  
FAX (4 15) 904-5 400  
TDD (415) 597-5885



January 6, 2014

Steve Rosen, Project Planner  
County of San Mateo - Planning and Building Department  
455 County Center, 2<sup>nd</sup> Floor  
Redwood City, CA 94063

**Subject: Planning Permit Application PLN2013-00495 (Kerry Burke)**

Dear Mr. Rosen:

Thank you for the County of San Mateo's PLN2013-00495 permit referral form, dated December 20, 2013, that we received on December 23, 2013 for Commission staff's review. The Project Description indicates that the permit application is for an after-the-fact grading permit and Coastal Development (CDP) to "legalize 7,200 cu/yards of completed grading to restore a bluff located at 20165 Cabrillo Highway, San Gregorio that was damaged without permits".

Just as a reminder, pursuant to Coastal Act Section 30601.3 (and as agreed upon by the applicant, County staff, and Commission staff) the Commission issued consolidated Emergency CDP G-2-13-0212 (ECDP) on September 12, 2013 for restoration of the bluff seaward of 20165 Cabrillo Highway. The work conducted under the ECDP is temporary until the applicant completes the process for a follow up CDP and obtains authorization from the Commission to keep the development in place permanently. The project applicant has submitted the required CDP application to Commission staff, which we received on November 13, 2013 in compliance with condition No. 12 of the ECDP. Therefore, the CDP for this project will be processed by the Commission, pending local approval of the after-the-fact grading permit as submitted to the County. A copy of staff's filing status letter, dated December 12, 2013, regarding this application is attached for your information.

Commission staff has reviewed the referral form for the grading permit and the attached as-built plan prepared by Sigma Prime Geosciences, Inc., dated November 11, 2013. Commission staff's primary concerns are presented below in summary.

- **Drainage:** The applicant should identify the location of the buried spring relative to the restoration area and describe how drainage of the site, on a permanent basis, is to be addressed.

Attachment K

- **Revegetation:** The applicant should prepare and provide a revegetation plan that includes complete planting palettes, container sizes, quantities, seeding rates, planting times, and sources; along with an irrigation plan. Commission staff further expects that the applicant provide a revegetation plan that includes monitoring of the progress and success of the revegetation at the site; and that they identify what measures will be undertaken to ensure its success.

You may contact me if you have any questions regarding this letter. We appreciate your time and efforts with this project. I can be reached by telephone at (415) 904-5260 or in writing at the address shown above in the letterhead.

Sincerely,



Renée Ananda  
Coastal Program Analyst  
North Central Coast District

Attachment

Cc: Kerry Burke  
Steve Monowitz, San Mateo County  
Camille Leung, San Mateo County



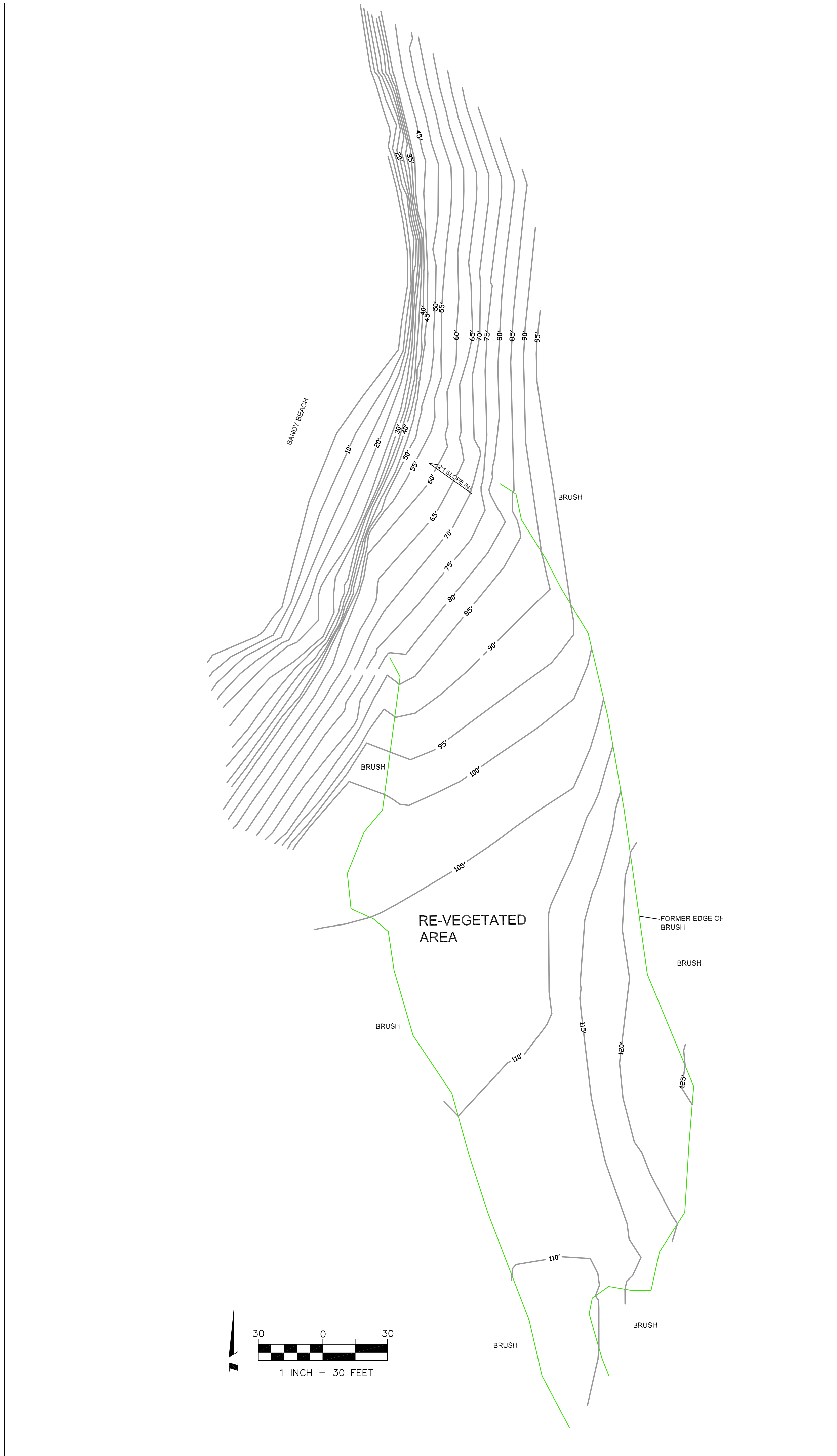

**LEGEND**

EXISTING 5' CONTOURS

**GENERAL NOTES**

1. EROSION CONTROL MEASURES THAT WERE PLACED IN 2013 PERFORMED AS PLANNED. THE SITE HAS EXPERIENCED NO EROSION AND VEGETATION IS NOW WELL-ESTABLISHED. THERE IS NO LONGER A NEED FOR EROSION CONTROL MEASURES.
2. INSPECTIONS WERE PERFORMED AT THE END OF EACH RAINY SEASON TO OBSERVE THE CONDITION OF THE RESTORED AREA.
3. ALL DRAINAGE NATURALLY OCCURRING WITHIN RESTORATION SITE. NO ADDITIONAL FACILITIES REQUIRED.
4. PLANS PREPARED AT THE REQUEST OF: CHHMB, LLC OWNER REPRESENTATIVES.
5. ORIGINAL SURVEY AND TOPOGRAPHY BY SIGMA PRIME, JULY 16, 2013.
6. ELEVATION DATUM ASSUMED.
7. AS-BUILT CONDITIONS BASED ON OBSERVATIONS MADE ON APRIL 21, 2017.

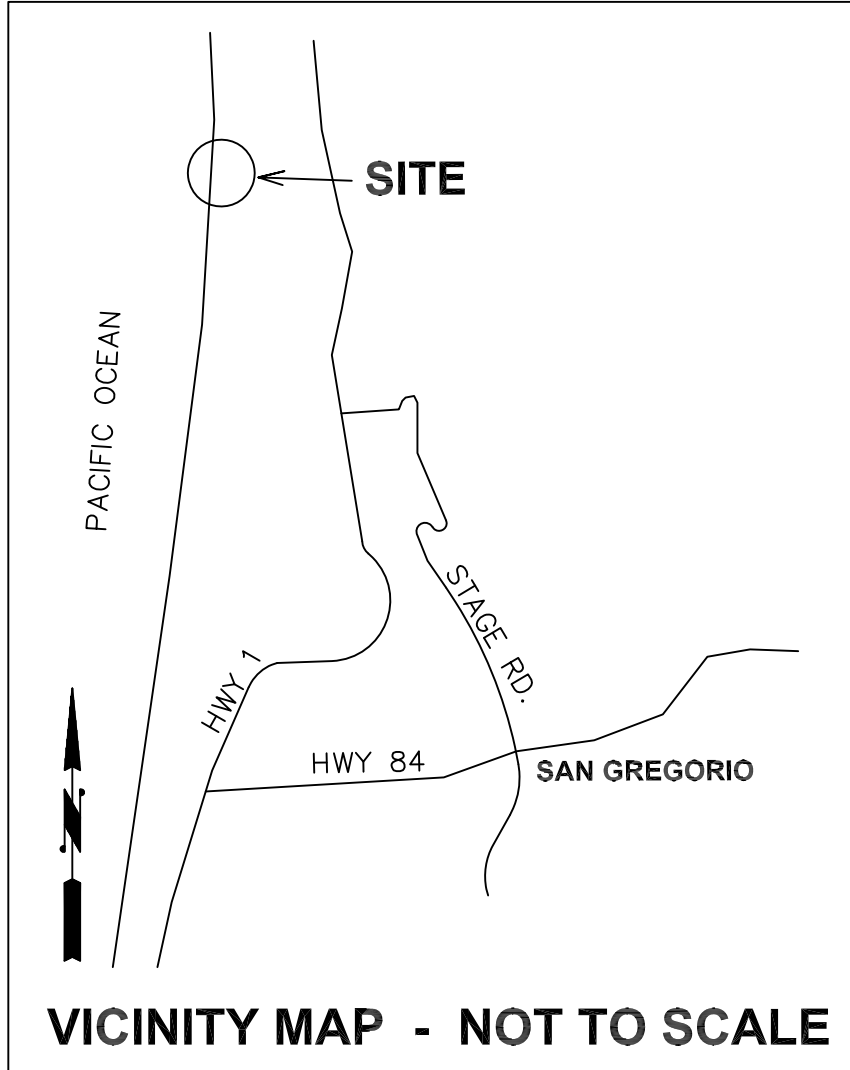

**SECTION AND DETAIL CONVENTION**

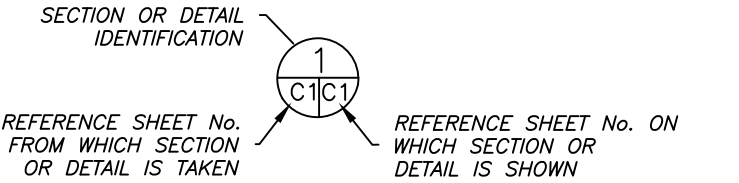

**Sigma Prime Geosciences, Inc.**  
 SIGMA PRIME GEOSCIENCES, INC.  
 332 PRINCETON AVENUE  
 HALF MOON BAY, CA 94019  
 (650) 728-3590  
 FAX 728-3593

DATE: 5-9-17
DRAWN BY: CMK
CHECKED BY: KLB
REV. DATE:
REV. DATE:
REV. DATE:

**COMPLETE RESTORATION AS-GRADED PLAN**  
 CHHMB PROPERTY  
 20165 CABRILLO HIGHWAY  
 SAN GREGORIO  
 APN 081-060-070



May 10, 2017

CHHMB LLC  
P. O. Box 123  
Half Moon Bay, CA 94019

Subject: Restoration Site Conditions: 20165 Cabrillo Highway  
File Numbers: PLN 2013-00495 and G-2-13-1111

***Narrative of emergency/permanent work completed on October 12, 2013***

An emergency Coastal development was granted by the County of San Mateo (PLN2013-00341) and the Coastal Commission (G-2-13-1111) to restore an area that had been graded by the previous landowner. The current landowner submitted a grading/restoration plan prepared to re-contour the area to pre-existing conditions to both agencies.

The restoration work per the approved plan was completed on October 12, 2013 for unpermitted grading done by the previous landowner. The work included utilizing 3 long-reach excavators that pulled the loose dirt from the beach in 4 separate lifts to trucks that then brought the soil back to the original location to be keyed in and placed into the restored area per the project plans with an excavator. Once the material was replaced per the project plans, the erosion control measures were installed including reseeding, jute netting and fiber roll placement. There was no rain during the restoration work. Grading restoration work was completed on October 9<sup>th</sup>. The site was reseeded on October 10<sup>th</sup> with a native seed mix recommended by WRA. Jute netting and erosion control measures were applied on October 11, 2013. Additional project work information/narrative is in the attached Coastal Commission letter dated November 11, 2013.

***Conditions Assessment***

We made a site visit on April 21, 2017 to check on the effectiveness of the erosion control measures and the re-vegetation efforts at the site of the restoration work that was performed in the Fall of 2013 per the approved plan C-1 Restoration work dated 8-14-2013. All site grading work was completed in the fall of 2013 per the permit requirements. The site has recovered very well. The erosion control measures, such as fiber rolls, jute netting and temporary swales were very effective in achieving the desired natural, uniform condition of the restoration site as shown in Sheet C-3, Complete Restoration/As-Graded Plan, dated 5-3-2017. Vegetation on the site is very healthy, and we understand that the biologist for this site will be preparing a letter discussing the topic of revegetation. The focus of Sigma Prime Geosciences' review by the project civil engineer is to provide information on the condition of the erosion and drainage of the restoration area of the property. Since the restoration work was completed, Sigma Prime has made annual site visits to monitor the site. The site has healed and been restored to a natural condition per the intent of the as graded restoration plan.





We noted no erosion occurring in or from the restoration area of the site. There were no gullies, rills, or other signs of erosion. The previously installed erosion control measures have achieved the desired results. The attached Sheet C-3, Complete Restoration/As-Graded Plan, indicates the current restored condition of the site and a completed job. The edge of the sea bluff exhibits no excessive erosion features. This project re-graded the disturbed area to near pre-existing conditions and has been restored.

### ***Drainage plan and Stormwater Plan***

Due to the success of the approved restoration plan design and implementation that has been observed over 3 winters there is no need for a drainage plan or a stormwater control plan. The site has been restored to the pre-existing condition. It has been re-vegetated and is stable without need for additional drainage structures. There is no impervious surface within the entire restoration area. The project is exempt from C3.C6 requirements and does not require a stormwater management plan. No drainage analysis was performed for this type of emergency restoration work to re-establish the natural condition of the site and that was accomplished without any permanent drainage structures or impervious surfaces. The restored and re-vegetated site slopes gently to the northwest. There is no evidence of erosion or surface water within the entire restoration area.

Despite the heavy rains this winter, there were no springs, seepage, nor erosion observed in the restoration area. The former spring/seepage that was observed in 2013 in the northwest corner of the area that was covered with fill, is no longer present. It appeared that the thick fill layer had been trapping and concentrating runoff and a seepage area. With the fill removed, per the restoration plan, this condition no longer exists. No drainage or stormwater structures are required for the site.

The site is now in very good condition. We do not see a need for any further erosion control or drainage measures for the restoration area. It is now returned to a stable, natural condition.

If you have any questions or comments about this letter report, please call me at (650) 728-3590.

Yours,  
Sigma Prime Geosciences

  
Charles Kissick, P.E.

Attachments:  
C-3 Restoration/As Graded Plan  
11-11-2013 Letter to CCC





May 12, 2017

Ms. Kerry Burke  
34 Amesport Landing  
Half Moon Bay, CA 94019

Re: Application Status of 'After-the-fact' Grading Permit and CDP at 20165 So. Cabrillo Highway, Half Moon Bay, California (CDP Application PLN2013-00495)

Dear Ms. Burke,

WRA, Inc. assisted in a completed restoration to a natural condition project at 20165 South Cabrillo Highway in Half Moon Bay, California. Subsequent an initial site visit in 2013 and the subsequent repairs to the hillside, WRA monitored the site to assess the success of the restored vegetation. This letter includes a brief summary of the site visits, repairs and the progression of vegetation regrowth within the restored area since 2013. The Nursery Memorandum, an observed plant species list and site photographs are attached.

#### *Initial Site Visit*

During the initial site visit, Ms. Leslie Lazarotti of WRA walked the area of the grading and earthmoving activities (repair area). Adjacent habitat consisted of northern coastal scrub dominated by coyote brush (*Baccharis pilularis*) and is considered as a common shrubland alliance on the California coast. Canopy cover in undisturbed portions of the property was nearly 100 percent with species cover and density similar to that reported by Baxter and Parker (1999) in their study on coastal scrub communities of the San Mateo coast (see photograph to the right). No wetlands, streams, or riparian habitat were observed in the area of the earthwork (WRA 2013).



#### *Repairs*

#### Revegetation

During the fall of 2013, emergency repairs were made to the hillside. As part of this repair effort, revegetation of the site was conducted. A restoration planting palette was recommended by WRA to the client (Table 1). Plant species included in the recommended seed mix are dominant species in the coastal scrub vegetation community and represented many of the species which were likely

Attachment N

present prior to disturbance of the hillside. In addition, WRA prepared a memorandum complete with local nursery information to convey the local availability of the plants recommended for the project site (Attachment A).

The revegetation was implemented in two phases in 2013. It began with the placement of the native soil and biodegradable matting/bars immediately following the completion of landform restoration construction. Then planting and seeding followed prior to the onset of the 2013-2014 rainy season.

Table 1. Recommended seed mix for the restored area (45 pounds total)

Common Name	Scientific Name	
California brome	<i>Bromus carinatus</i>	Native
Meadow barley	<i>Hordeum brachyantherum</i>	Native
Three week fescue	<i>Festuca [Vulpia] microstachys</i>	Native
Tomcat clover	<i>Trifolium willdenovii</i>	Native

### Drainage

No additional drainage work was conducted on-site. Once the landform restoration was completed the site was left to allow for the natural recarving of drainage channels, allowing the present topography to direct drainage flow. Access trails were preserved for monitoring purposes.

### *Results*

Following the coastal bluff restoration and repair work, WRA conducted site visits to assess the progression of vegetation maturation within the restored area. A total of eight site visits were conducted by WRA between 2014 and 2017: February 21, April 11, and August 25, 2014; April 9 and June 29, 2015; June 3, 2016, and January 19 and May 1, 2017.



Over the course of four years, the restored site has progressively increased in vegetative cover, with a heavy dominance on native plant species. Site visit summaries are described in Table 2. An observed species list for the restored area is included in Attachment B. A comprehensive set of timeline photos are included in

Attachment C.

Table 2. Summary of monitoring site visit observations and findings

Site Visit	Percent Vegetative Cover*	Dominant Plant Species	General Comments
February 21, 2014	20%	Three week fescue, meadow barley, and poison oak.	Small amounts of vegetation emerging through the erosion control fabric through repair area, concentrated within the flat terrace portion.
April 11, 2014	50%/20%*	Three week fescue, meadow barley, and poison oak	A small amount of wild cucumber ( <i>Marah</i> sp.) was observed. Grass species are becoming more robust. The flatter portion of the site is increasingly vegetated, while the sloped section shows evidence of establishment.
August 25, 2014	50%/30%	Three week fescue, meadow barley, and poison oak	Seaside woolly sunflower ( <i>Erophylum staechadifolium</i> ) is encroaching along the edges of the restored area. Grasses form a dense, dried mat along the flatter sections of the site and are more evident along the slope to the beach.
April 9, 2014	70%/45%	Meadow barley, seaside woolly sunflower, yellow bush lupine, and poison oak.	Additional plants present: coyote brush ( <i>Baccharis pilularis</i> ), blue witch ( <i>Solanum umbelliferum</i> ), and ladies' tobacco ( <i>Pseudognaphalium californicum</i> ).
June 29, 2015	70%/50%	Meadow barley, seaside woolly sunflower, yellow bush lupine, three week fescue, and poison oak.	Additional plants present: coyote brush, blue witch, West Coast Canada goldenrod, and California blackberry ( <i>Rubus ursinus</i> ).
June 3, 2016	80%/55%	Meadow barley, seaside woolly sunflower, yellow bush lupine, poison oak, and cottonbatting plant ( <i>Pseudognaphalium stramineum</i> ).	Additional plants present: Henderson's angelica ( <i>Angelica hendersonii</i> ),
January 19, 2017	85%/60%	Meadow Barley, seaside woolly sunflower, yellow bush lupine, poison oak.	Additional plants present: three week fescue, blue witch
May 1, 2017	85%/75%	Meadow Barley, seaside woolly, yellow bush lupine, poison oak, coyote brush.	Additional plants present: douglas iris

\*Qualitative based on analysis of the site and photographic assessment.

\*\* % vegetative cover of the flatter, upper portion of the site/%vegetative cover of the slope towards the beach





Photographs: 1) Three week fescue observed within the restored area on April 11, 2014. 2) Drainage furrows, observed during the June 24, 2015 site visit. 3) Completely vegetated section of the site along a steep slope, including a mix of meadow barley, seaside woolly, yellow bush lupine, poison oak, coyote brush, and others observed during the May 1, 2017 site visit.

### *Discussion*

#### Revegetation

Following repair and restoration activities during the fall of 2013, the restored area has steadily increased in percent cover of vegetation and is currently dominated by the following native species: meadow barley, seaside woolly, yellow bush lupine, poison oak, and coyote brush. Of the species consistently documented as dominants within the restored area, meadow barley was the only species included as part of the seed mix applied to the site. Seaside woolly sunflower, yellow bush lupine, poison oak, and many of the subdominant plant species present on the site are typically found in coastal scrub communities and were not included in the seed mix. Thus, these species were naturally recruited, either by the existing seedbank or local dispersal, into suitably restored habitat conditions. Non-natives present within the restored area include tall fescue (*Festuca arundinacea*), sea fig (*Carpobrotus chilensis*), bull thistle (*Cirsium vulgare*), and common mustard (*Brassica rapa*).



The plant species composition within the restored area is comparable to the composition of surrounding coastal scrub habitat. In addition, over the course of the four years of monitoring, steady plant growth was observed and the restored area is considered as densely vegetated as the surrounding coastal scrub habitat (Attachment C). The natural successional processes were first observed on the edges of the restored area; new recruits of coast sagebrush (*Artemisia californica*), coyote brush, and California blackberry (*Rubus ursinus*) are occurring in a concentrated fringe along the outer edge (see photograph to the right). This then spread throughout the site, allowing for full regrowth to occur.

## Drainage

Drainage is a concern due to the potential for additional soil and rock to erode onto the terrace or beach adjacent to the site. As anticipated, drainage paths following the natural ridges in the topography were observed as early as the June 24, 2015 site visit (Photograph B). No erosion events within the restored area were observed. Some erosion appeared to be occurring on the outer edge of the coastal bluff as the area recalibrates natural drainage paths, but it does not appear to have increased since it was noted in 2014. Furthermore, the most recent rainy season consisted of extremely wet and prolonged rain events. As no notable disturbance was observed at the conclusion of the 2016-2017 rainy season, the site is evidenced to be fairly stable, most likely due to the vegetated state of the site.

## *Summary*

The native coastal seed mix applied on the project site was successful in revegetating the project site as well as encouraging the growth of additional native plants not included in the original mix. As evidenced above, and in Attachments A-C, the site has progressively become more vegetated and is anticipated to continue to do so. Natural drainage patterns are present along the natural furrows, are fully vegetated, and there is no evidence of any erosion. The site appears to be fully vegetated and any additional plant growth will further minimize future erosion potential. The completed project has rehabilitated the site.

Sincerely,

Leslie Lazarotti, MS  
Senior Associate, WRA

Enclosure

Attachment A: Local Nursery Information Memorandum  
Attachment B: Observed Plant Species  
Attachment C: Site Photographs

References:

Baxter, J.W. and V.T. Parker. 1999. Canopy gaps, zonation, and topographic structure: a northern coastal scrub community on California coastal bluffs. *Madrone* 46: 69-79.

## Memorandum

**To:** Dante Silvestri

**From:** Leslie Lazarotti  
lazarotti@wra-ca.com

**Cc:**

**Subject:** Local Nursery Information

**Date:** August 15, 2013

Information for local nurseries is included below. I hope this can provide a good foundation for sourcing the plants for the Project Site. Thank you.

<b>Central Coast Wilds</b>				
<b>COMMON NAME</b>	<b>BOTANICAL NAME</b>	<b>AVAILABLE SIZE</b>	<b>PRICE EACH*</b>	<b>GEOGRAPHICAL ORIGIN OF PLANT OR PARENT</b>
MUGWORT	<i>ARTEMISIA DOUGLASIANA</i>	Gallon	\$3.95	Napa Valley
COYOTE BUSH	<i>BACCHARIS PILULARIS</i>	Gallon	\$5.95	Liddell Creek/Pajaro Valley
BLUEBLOSSOM	<i>CEANOTHUS THYRSIFLORUS</i>	Gallon	\$3.95	Carmel Valley
SEASIDE DAISY	<i>ERIGERON GLAUCUS</i>	Gallon	\$5.95	Liddell Creek
SEASIDE WOOLY SUNFLOWER	<i>ERIOPHYLLUM STAECHADIFOLIUM</i>	Gallon	\$5.95	Liddell Creek
YELLOW LUPINE	<i>LUPINUS ARBOREUS</i>	Gallon	\$3.95	unknown
			<b>TOTAL:</b>	
<b>Elkhorn</b>				
<b>COMMON NAME</b>	<b>BOTANICAL NAME</b>	<b>AVAILABLE SIZE</b>	<b>PRICE EACH*</b>	<b>GEOGRAPHICAL ORIGIN OF PLANT OR PARENT</b>
COASTAL MUGWORT	<i>ARTEMISIA PYCNOCEPHALA</i>	1 GALLON	\$3.85	Monterey County
COYOTE BUSH	<i>BACCHARIS PILULARIS</i>	1 GALLON	\$3.60	elkhorn ranch Monterey County
BLUEBLOSSOM	<i>CEANOTHUS THYRSIFLORUS</i>	1 GALLON	\$3.60	Santa Cruz County, Watsonville area
SEASIDE DAISY	<i>ERIGERON GLAUCUS</i>	1 GALLON	\$3.35	Carmel area, Monterey County
SEASIDE WOOLY SUNFLOWER	<i>ERIOPHYLLUM STAECHADIFOLIUM</i>	1 GALLON	\$3.95	elkhorn ranch Monterey County, 2nd batch unknown
YELLOW LUPINE	<i>LUPINUS ARBOREUS</i>	5 GALLON	\$13.25	unknown
			<b>TOTAL:</b>	
<b>Go Native</b>				
<b>COMMON NAME</b>	<b>BOTANICAL NAME</b>	<b>AVAILABLE SIZE</b>	<b>PRICE EACH*</b>	<b>GEOGRAPHICAL ORIGIN OF PLANT OR PARENT</b>
MUGWORT	<i>ARTEMISIA DOUGLASIANA</i>	1 gal	\$6.00	Pacifica, San Mateo Co.
CALIFORNIA SAGE	<i>ARTEMISIA CALIFORNICA</i>	1 gal	\$6.00	Pacifica, San Mateo Co.
COYOTE BUSH <sup>2</sup>	<i>BACCHARIS PILULARIS</i>	1 gal	\$6.00	Monatara & Pacifica, San Mateo Co.
BLUEBLOSSOM	<i>CEANOTHUS THYRSIFLORUS</i>	1 gal	\$6.00	Pacifica, San Mateo Co.
SEASIDE DAISY	<i>ERIGERON GLAUCUS</i>	D19	\$3.00	Pacifica, San Mateo Co.
SEASIDE WOOLY SUNFLOWER	<i>ERIOPHYLLUM STAECHADIFOLIUM</i>	D19	\$3.00	SF
YELLOW LUPINE	<i>LUPINUS ARBOREUS</i>	1 gal	\$6.00	Pacifica, San Mateo Co.

\*Listed prices are based on a small order. Prices may go down for larger orders. Nurseries may also be able to grow plants at different sizes from those listed; price will likely change.

# Attachment N



**Attachment B. Plant species observed in the restoration area 2014-2016**

Scientific Name	Family	Common Name	Origin	Form	Rarity Status	CAL-IPC Status
<i>Achillea millefolium</i>	Asteraceae	Yarrow	native	perennial herb	-	-
<i>Acmispon wrangelianus</i>	Fabaceae	Chilean trefoil	native	annual herb	-	-
<i>Angelica hendersonii</i>	Apiaceae	Henderson's angelica	native	perennial herb	-	-
<i>Anthemis cotula</i>	Asteraceae	Dog fennel	non-native (invasive)	annual herb	-	-
<i>Artemisia californica</i>	Asteraceae	Coastal sage brush	native	shrub	-	-
<i>Baccharis pilularis</i>	Asteraceae	Coyote brush	native	shrub	-	-
<i>Brassica nigra</i>	Brassicaceae	Black mustard	non-native (invasive)	annual herb	-	Moderate
<i>Brassica rapa</i>	Brassicaceae	Common mustard	non-native (invasive)	annual herb	-	Limited
<i>Bromus catharticus</i> var. <i>catharticus</i>	Poaceae	Rescue grass	non-native	annual, perennial grass	-	-
<i>Bromus diandrus</i>	Poaceae	Ripgut brome	non-native (invasive)	annual grass	-	Moderate
<i>Bromus hordeaceus</i>	Poaceae	Soft chess	non-native (invasive)	annual grass	-	Limited
<i>Bromus tectorum</i>	Poaceae	Downy chess	non-native (invasive)	annual grass	-	High
<i>Carpobrotus chilensis</i>	Aizoaceae	Sea fig	non-native (invasive)	perennial herb	-	Moderate
<i>Cirsium brevistylum</i>	Asteraceae	Indian thistle	native	perennial herb	-	-
<i>Cirsium vulgare</i>	Asteraceae	Bullthistle	non-native (invasive)	perennial herb	-	Moderate
<i>Conium maculatum</i>	Apiaceae	Poison hemlock	non-native (invasive)	perennial herb	-	Moderate
<i>Cortaderia jubata</i>	Poaceae	Andean pampas grass	non-native (invasive)	perennial grass	-	High

Scientific Name	Family	Common Name	Origin	Form	Rarity Status	CAL-IPC Status
<i>Cotula coronopifolia</i>	Asteraceae	Brass buttons	non-native (invasive)	perennial herb	-	Limited
<i>Dactylis glomerata</i>	Poaceae	Orchardgrass	non-native (invasive)	perennial grass	-	Limited
<i>Erigeron canadensis</i>	Asteraceae	Canada horseweed	native	annual herb	-	-
<i>Erigeron glaucus</i>	Asteraceae	Seaside daisy	native	perennial herb	-	-
<i>Eriophyllum staechadifolium</i>	Asteraceae	Seaside woolly sunflower	native	perennial herb	-	-
<i>Eschscholzia californica</i>	Papaveraceae	California poppy	native	annual, perennial herb	-	-
<i>Festuca arundinacea</i>	Poaceae	Tall fescue	non-native (invasive)	perennial grass	-	Moderate
<i>Festuca microstachys</i>	Poaceae	Three weeks fescue	native	annual grass	-	-
<i>Festuca myuros</i>	Poaceae	Rattail sixweeks grass	non-native (invasive)	annual grass	-	-
<i>Frangula californica</i> ssp. <i>californica</i>	Rhamnaceae	California coffeeberry	native	shrub	-	-
<i>Heracleum maximum</i>	Apiaceae	Common cowparsnip	native	perennial herb	-	-
<i>Hesperocyparis macrocarpa</i>	Cupressaceae	Monterey cypress	native	tree	Rank 1B.2	-
<i>Iris douglasiana</i>	Iridaceae	Douglas iris	native	perennial herb	-	-
<i>Lupinus arboreus</i>	Fabaceae	Coastal bush lupine	native	shrub	-	-
<i>Marah fabacea</i>	Cucurbitaceae	California man-root	native	perennial herb, vine	-	-
<i>Mimulus aurantiacus</i>	Phrymaceae	Sticky monkeyflower	native	shrub	-	-
<i>Oemleria cerasiformis</i>	Rosaceae	Oso berry	native	shrub	-	-
<i>Phalaris</i> sp.	Poaceae	Canarygrass	non-native	annual grass	-	-

Scientific Name	Family	Common Name	Origin	Form	Rarity Status	CAL-IPC Status
<i>Pinus radiata</i>	Pinaceae	Monterey pine	native	tree	Rank 1B.1	-
<i>Plantago maritima</i>	Plantaginaceae	Maritime plantain	native	perennial herb	-	-
<i>Polypogon interruptus</i>	Poaceae	Ditch beard grass	non-native	perennial grass	-	-
<i>Polypogon monspeliensis</i>	Poaceae	Annual beard grass	non-native (invasive)	annual grass	-	Limited
<i>Pseudognaphalium californicum</i>	Asteraceae	Ladies' tobacco	native	annual, perennial herb	-	-
<i>Pseudognaphalium stramineum</i>	Asteraceae	Cottonbatting plant	native	perennial herb	-	-
<i>Pteridium aquilinum</i> var. <i>pubescens</i>	Dennstaedtiaceae	Western bracken fern	native	fern	-	-
<i>Rubus ursinus</i>	Rosaceae	California blackberry	native	vine, shrub	-	-
<i>Rumex crassus</i>	Polygonaceae	Willow leaved dock	native	perennial herb	-	-
<i>Sambucus racemosa</i> var. <i>racemosa</i>	Adoxaceae	Red elderberry	native	shrub	-	-
<i>Sanicula crassicaulis</i>	Apiaceae	Pacific sanicle	native	perennial herb	-	-
<i>Scrophularia californica</i>	Scrophulariaceae	California bee plant	native	perennial herb	-	-
<i>Solanum furcatum</i>	Solanaceae	Forked nightshade	non-native	perennial herb, shrub	-	-
<i>Solanum umbelliferum</i>	Solanaceae	Blue witch	native	shrub	-	-
<i>Solidago elongata</i>	Asteraceae	West coast canada goldenrod	native	perennial herb	-	-
<i>Sonchus asper</i> ssp. <i>asper</i>	Asteraceae	Sow thistle	non-native (invasive)	annual herb	-	-
<i>Sonchus oleraceus</i>	Asteraceae	Sow thistle	non-native	annual herb	-	-



Scientific Name	Family	Common Name	Origin	Form	Rarity Status	CAL-IPC Status
<i>Spergularia macrotheca</i> var. <i>macrotheca</i>	Caryophyllaceae	Sticky sand spurry	native	perennial herb	-	-
<i>Stachys</i> sp.	Lamiaceae	Hedgenettle	native	perennial herb	-	-
<i>Tetragonia tetragonoides</i>	Aizoaceae	New zealand spinach	native	annual, perennial herb	-	-
<i>Toxicodendron diversilobum</i>	Anacardiaceae	Poison oak	native	vine, shrub	-	-
<i>Vicia gigantea</i>	Fabaceae	Giant vetch	native	perennial herb	-	-



Above: July 29, 2013; Overlooking the graded area along the coastal bluff.

Below: August 25, 2014; Just over one year later, the coastal bluff has been restored and native vegetation has established.





Above: July 29, 2013; The graded slope down to the beach was stripped of vegetation.

Below: April 11, 2014; The slope to the beach has been stabilized and small amounts of vegetation and grass are emerging through the erosion control material.







Above: August 25, 2014; The amount of vegetative cover on the slope to the beach continues to increase.

Below: June 24, 2015; Native shrubs are now established down the slope to the beach, increasing hillside stability.





Above: July 29, 2013; the site was thoroughly stripped of all vegetation and graded to a lower elevation.

Below: April 11, 2014; As evidenced, repair actions have restored the elevation to the site and the initial growth from the applied seed mix is occurring.







April 9, 2015 (above) and June 24, 2015 (below). The juxtaposition of these two photographs shows native shrub growth over two months. Seaside woolly sunflower, coyote brush and poison oak from the adjacent coastal scrub habitat have become established in the restored area. In addition, the furrows crossing the area are becoming vegetated.







Above: June 3, 2016. The amount of vegetation along the sloped site continues to increase.

Below: May 1, 2017. The same area as above represents full regrowth of coastal shrub, consistent with the vegetated state of the surrounding lands.

